

MONOBLOCK HORIZONTAL  
CENTRIFUGAL PUMPS



Household Fire Fighting Irrigation Circulation

PST



# RANELLI

Water Systems

PST MONOBLOCK HORIZONTAL  
CENTRIFUGAL PUMPS  
CONSTRUCTION FEATURES

**APPLICATION**

- Cooling water
- Water supply / distribution
- Drainage
- Irrigation
- Fire-fighting systems, standard supply with counter-flanges

**PUMP SPECIFICATIONS**

- Discharge flange diameter: DN32-DN80 mm
- Capacity Q range: 4.5m<sup>3</sup>/h-240m<sup>3</sup>/h (50HZ)(60HZ)
- Head H range: 10m-92.5m
- Operating speed: 2900rpm (50HZ) 3450rpm (60HZ)

**CONSTRUCTION FEATURES**

- Main dimensions: apply to EN733 (DIN24255) standard and back pull out type
- Casing structure: End suction, center radial discharge
- Flange pressure rate: ISO7005.2 PN1.6MPa
- Shaft seal: single mechanical seal (graphite / silicon carbide / ceramic / NBR / FPM / SS304 / SS3.6) According to standard EN 12756
- Driven shaft: pump and motor flanged together to form a close-coupled unit, with common shaft and standard motor with sleeve shaft for 22KW and above.

**ON REQUEST**

- Other operating voltages and frequencies
- Special mechanical seal; special liquids
- Special temperature

**OPERATION CONDITIONS**

- Working temperature range: -10°C ~+90°C
- Max. allowable working pressure (MAWP): 10bar
- Hydrostatic test pressure = 1.3 times the maximum discharge pressure, but not exceed 13bar

**MOTOR SPECIFICATIONS**

Totally enclosed fan cooled asynchronous induction motor

Winding: 50HZ is adoptable

|         |          |                              |
|---------|----------|------------------------------|
| 3 Phase | 2-4HP    | 220-240VD / 280-420VY - 50HZ |
|         | 5.5-50HP | 280-420VD / 660-725VY - 50HZ |
| 1 Phase | 2-5.5HP  |                              |

- Degree of motor protection: IP55 (IEC60034-5)
- Insulation Class: F
- Duty: S1 continuous duty operation
- Altitude shall not exceed 1000m above seal-level (IEC60034-1)
- Allowed air temperature between -20°C and 40°C (IEC60034-1)

**ON REQUEST**

Totally enclosed fan cooled asynchronous induction motor

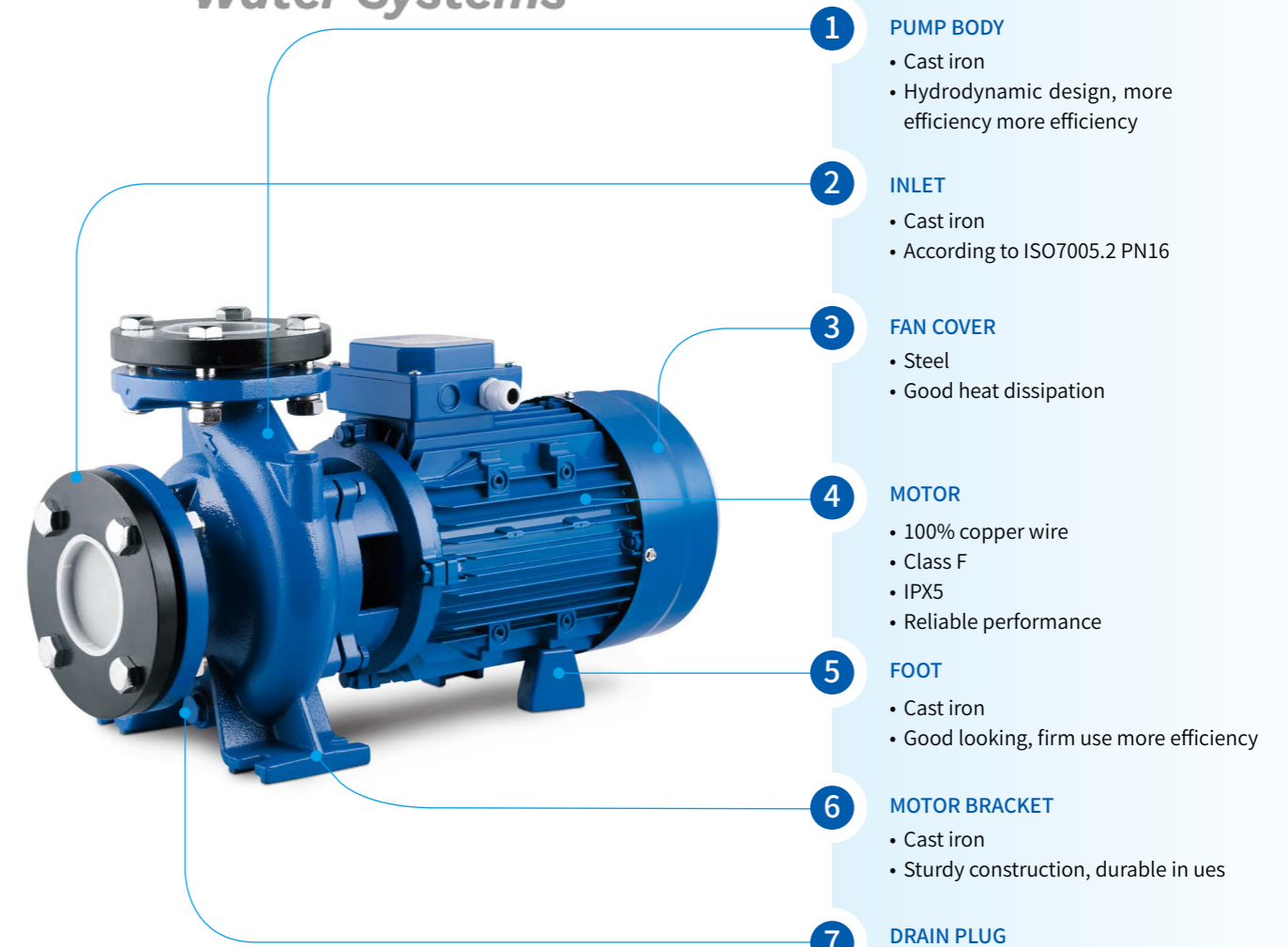

- PUMP BODY**
  - Cast iron
  - Hydrodynamic design, more efficiency more efficiency
- INLET**
  - Cast iron
  - According to ISO7005.2 PN16
- FAN COVER**
  - Steel
  - Good heat dissipation
- MOTOR**
  - 100% copper wire
  - Class F
  - IPX5
  - Reliable performance
- FOOT**
  - Cast iron
  - Good looking, firm use more efficiency
- MOTOR BRACKET**
  - Cast iron
  - Sturdy construction, durable in uses
- DRAIN PLUG**
  - Brass
  - Corrosion resistance
  - Durable in use

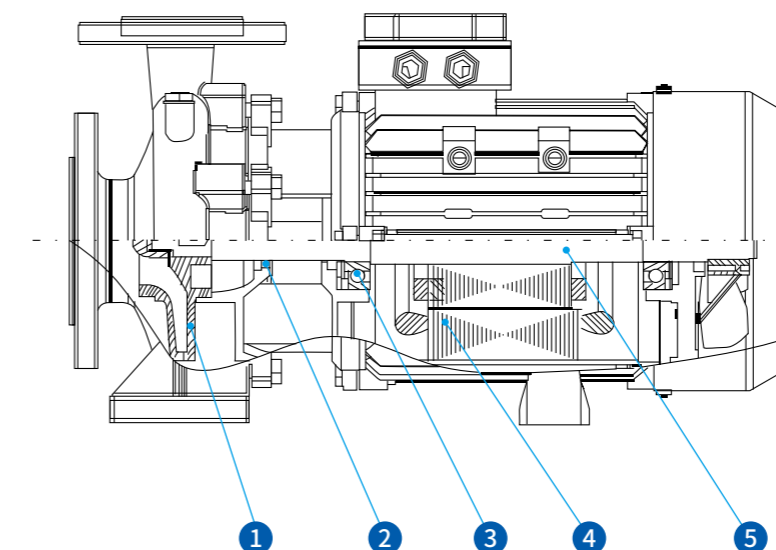

- IMPELLER:**
  - Cast iron (On request: AISI304/AISI1316/Bronze)
- MECHANICAL SEAL:**
  - (On request: special mechanical seal)
- BEARING:**
  - NSK ball bearing
- MOTOR:**
  - 100% copper wire, Class F
- SHAFT:**
  - AISI1045 (On request: AISI420/AISI304)

| MODEL<br>MODELO<br>MODÈLE | DN<br>mm | Power<br>Potencia<br>Puissance<br>kw hp |      | Q=DELIVERY/CAUDAL/DÉBIT |      |      |      |      |      |      |      |      |      |      |      |      |      |      |      |      |      |
|---------------------------|----------|---|------|-------------------------|------|------|------|------|------|------|------|------|------|------|------|------|------|------|------|------|------|
|                           |          |   |      | us<br>gpm               | 0    | 26   | 40   | 66   | 79   | 106  | 119  | 159  | 185  | 211  | 238  | 317  | 370  | 396  | 476  | 529  | 608  |
|                           |          |   |      | l/min                   | 0    | 100  | 150  | 250  | 300  | 400  | 450  | 600  | 700  | 800  | 900  | 1200 | 1400 | 1500 | 1800 | 2000 | 2300 |
| PST 32-125/07             | 50x32    | 0.75                                    | 1    | 17.5                    | 16.7 | 15   | 12   | 9    | -    | -    | -    | -    | -    | -    | -    | -    | -    | -    | -    | -    |      |
| PST 32-125/11             | 50x32    | 1.1                                     | 1.5  | 22                      | 21   | 19.7 | 16.5 | 14.5 | 9    | -    | -    | -    | -    | -    | -    | -    | -    | -    | -    | -    |      |
| PST 32-160/15             | 50x32    | 1.5                                     | 2    | 25.4                    | 23.7 | 22.5 | 18.5 | 15.8 | -    | -    | -    | -    | -    | -    | -    | -    | -    | -    | -    | -    |      |
| PST 32-160/22             | 50x32    | 2.2                                     | 3    | 31                      | 29.6 | 28.5 | 24.5 | 22   | 15   | -    | -    | -    | -    | -    | -    | -    | -    | -    | -    | -    |      |
| PST 32-160/30             | 50x32    | 3                                       | 4    | 35                      | 34.3 | 32.5 | 28   | 25.5 | 19   | 15   | -    | -    | -    | -    | -    | -    | -    | -    | -    | -    |      |
| PST 32-200/30             | 50x32    | 3                                       | 4    | 44.2                    | 42   | 39.8 | 35.2 | 32.2 | 24.6 | 19.8 | -    | -    | -    | -    | -    | -    | -    | -    | -    | -    |      |
| PST 32-200/40             | 50x32    | 4                                       | 5.5  | 54.5                    | 52   | 50   | 45.5 | 42.3 | 35   | 30.3 | -    | -    | -    | -    | -    | -    | -    | -    | -    | -    |      |
| PST 32-250/55             | 50x32    | 5.5                                     | 7.5  | 60                      | 59.5 | 59   | 55   | 50.2 | 34.5 | -    | -    | -    | -    | -    | -    | -    | -    | -    | -    | -    |      |
| PST 32-250/75             | 50x32    | 7.5                                     | 10   | 69.5                    | 69   | 68.5 | 66   | 63   | 53   | -    | -    | -    | -    | -    | -    | -    | -    | -    | -    | -    |      |
| PST 32-250/92             | 50x32    | 9.2                                     | 12.5 | 75                      | 75   | 74.5 | 72   | 69   | 59   | -    | -    | -    | -    | -    | -    | -    | -    | -    | -    | -    |      |
| PST 32-250/110            | 50x32    | 11                                      | 15   | 90                      | 89.5 | 88   | 82   | 78   | 66   | -    | -    | -    | -    | -    | -    | -    | -    | -    | -    | -    |      |
| PST 32-250/150            | 50x32    | 15                                      | 20   | 97                      | 96.5 | 96   | 90   | 86   | 73   | -    | -    | -    | -    | -    | -    | -    | -    | -    | -    | -    |      |
| PST 32-250/55D            | 50x32    | 5.5                                     | 7.5  | 79.5                    | 74.7 | 71.8 | 63   | 56   | 37.5 | -    | -    | -    | -    | -    | -    | -    | -    | -    | -    | -    |      |
| PST 32-250/75D            | 50x32    | 7.5                                     | 10   | 95                      | 93   | 91   | 83   | 76   | 57.8 | -    | -    | -    | -    | -    | -    | -    | -    | -    | -    | -    |      |
| PST 40-125/11             | 65x40    | 1.1                                     | 1.5  | 14.7                    | -    | -    | -    | 13   | 11.5 | 10.1 | 5.8  | -    | -    | -    | -    | -    | -    | -    | -    | -    |      |
| PST 40-125/15             | 65x40    | 1.5                                     | 2    | 18.1                    | -    | -    | -    | 17   | 15   | 13.9 | 10   | 6    | -    | -    | -    | -    | -    | -    | -    | -    |      |
| PST 40-125/22             | 65x40    | 2.2                                     | 3    | 24.5                    | -    | -    | -    | 23.2 | 21.5 | 20.2 | 16   | 13   | 8.3  | -    | -    | -    | -    | -    | -    | -    |      |
| PST 40-160/30             | 65x40    | 3                                       | 4    | 31.8                    | -    | -    | -    | 29.5 | 27.5 | 26.3 | 21.5 | 17.5 | -    | -    | -    | -    | -    | -    | -    | -    |      |
| PST 40-160/40             | 65x40    | 4                                       | 5.5  | 38                      | -    | -    | -    | 36   | 34   | 33   | 28.5 | 25   | 20.1 | -    | -    | -    | -    | -    | -    | -    |      |
| PST 40-200/55             | 65x40    | 5.5                                     | 7.5  | 46                      | -    | -    | -    | 43.8 | 41.3 | 40.1 | 35   | 30   | -    | -    | -    | -    | -    | -    | -    | -    |      |
| PST 40-200/75             | 65x40    | 7.5                                     | 10   | 57                      | -    | -    | -    | 53.6 | 51.5 | 50   | 45   | 41   | 36.5 | -    | -    | -    | -    | -    | -    | -    |      |
| PST 40-250/92             | 65x40    | 9.2                                     | 12.5 | 64                      | -    | -    | -    | 59   | 56.5 | 55   | 49.5 | 45   | 39.8 | -    | -    | -    | -    | -    | -    | -    |      |
| PST 40-250/110            | 65x40    | 11                                      | 15   | 72                      | -    | -    | -    | 67.5 | 65   | 63.5 | 57.5 | 52.2 | 47   | -    | -    | -    | -    | -    | -    | -    |      |
| PST 40-250/150            | 65x40    | 15                                      | 20   | 84.5                    | -    | -    | -    | 79.3 | 77.3 | 75.2 | 70   | 66   | 61   | -    | -    | -    | -    | -    | -    | -    |      |
| PST 40-250/185            | 65x40    | 18.5                                    | 25   | 90                      | -    | -    | -    | 85.5 | 82.8 | 80.7 | 75.8 | 70.5 | 66.5 | -    | -    | -    | -    | -    | -    | -    |      |
| PST 50-125/22             | 65x50    | 2.2                                     | 3    | 17                      | -    | -    | -    | -    | -    | -    | 15.4 | 14   | 12.8 | 11.5 | 6.5  | -    | -    | -    | -    | -    |      |
| PST 50-125/30             | 65x50    | 3                                       | 4    | 20                      | -    | -    | -    | -    | -    | -    | 18.8 | 18   | 17   | 15.6 | 11   | -    | -    | -    | -    | -    |      |
| PST 50-125/40             | 65x50    | 4                                       | 5.5  | 24                      | -    | -    | -    | -    | -    | -    | 23.1 | 23   | 21.5 | 20.3 | 15.8 | 11.8 | -    | -    | -    | -    |      |
| PST 50-160/55             | 65x50    | 5.5                                     | 7.5  | 32                      | -    | -    | -    | -    | -    | -    | 30.6 | 30   | 28   | 26.6 | 20.5 | 14.8 | -    | -    | -    | -    |      |
| PST 50-160/75             | 65x50    | 7.5                                     | 10   | 40                      | -    | -    | -    | -    | -    | -    | 38   | 37   | 36   | 34.4 | 29   | 24   | 21   | -    | -    | -    |      |
| PST 50-200/92             | 65x50    | 9.2                                     | 12.5 | 50.5                    | -    | -    | -    | -    | -    | -    | 46.8 | 45   | 43   | 40.9 | 32.5 | 26.7 | -    | -    | -    | -    |      |
| PST 50-200/110            | 65x50    | 11                                      | 15   | 57.5                    | -    | -    | -    | -    | -    | -    | 53.5 | 52   | 50   | 47.5 | 40   | 34   | 29   | -    | -    | -    |      |
| PST 50-200/150            | 65x50    | 15                                      | 20   | 62                      | -    | -    | -    | -    | -    | -    | 58   | 56.5 | 54.5 | 52   | 44.5 | 39   | 35.5 | -    | -    | -    |      |
| PST 50-250/150            | 65x50    | 15                                      | 20   | 68.5                    | -    | -    | -    | -    | -    | -    | 64   | 63   | 61.5 | 59   | 50   | 41   | -    | -    | -    | -    |      |
| PST 50-250/185            | 65x50    | 18.5                                    | 25   | 79                      | -    | -    | -    | -    | -    | -    | 75.8 | 74.8 | 74   | 71.5 | 63.5 | 55.5 | 47   | -    | -    | -    |      |
| PST 50-250/220            | 65x50    | 22                                      | 30   | 89.5                    | -    | -    | -    | -    | -    | -    | 86   | 85.3 | 84   | 81.5 | 73.5 | 63.5 | 57   | -    | -    | -    |      |
| PST 65-125/40             | 80x65    | 4                                       | 5.5  | 19                      | -    | -    | -    | -    | -    | -    | -    | -    | 17.3 | 16.8 | 14.5 | 13   | 11.8 | -    | -    | -    |      |
| PST 65-125/55             | 80x65    | 5.5                                     | 7.5  | 23                      | -    | -    | -    | -    | -    | -    | -    | -    | 21.3 | 20.9 | 19   | 17.5 | 16.7 | 13.7 | -    | -    |      |
| PST 65-125/75             | 80x65    | 7.5                                     | 10   | 27                      | -    | -    | -    | -    | -    | -    | -    | -    | 26   | 25.6 | 24.5 | 23   | 22.5 | 20   | 18   | -    |      |
| PST 65-160/92             | 80x65    | 9.2                                     | 12.5 | 33                      | -    | -    | -    | -    | -    | -    | -    | -    | 31.5 | 30   | 28   | 27.1 | 24   | 21.5 | -    | -    |      |
| PST 65-160/110            | 80x65    | 11                                      | 15   | 36                      | -    | -    | -    | -    | -    | -    | -    | -    | 34.5 | 33   | 31.5 | 30.8 | 28   | 25.5 | -    | -    |      |
| PST 65-160/150            | 80x65    | 15                                      | 20   | 42                      | -    | -    | -    | -    | -    | -    | -    | -    | 41   | 40   | 38.5 | 37.8 | 35   | 33   | 29.5 | -    |      |
| PST 65-200/150            | 80x65    | 15                                      | 20   | 45                      | -    | -    | -    | -    | -    | -    | -    | -    | 45.5 | 43   | 41   | 40.2 | 36.5 | 34   | -    | -    |      |
| PST 65-200/185            | 80x65    | 18.5                                    | 25   | 52                      | -    | -    | -    | -    | -    | -    | -    | -    | 52.3 | 51   | 49   | 48.2 | 44.5 | 42   | -    | -    |      |
| PST 65-200/220            | 80x65    | 22                                      | 30   | 59                      | -    | -    | -    | -    | -    | -    | -    | -    | 59.5 | 58   | 56   | 55   | 52   | 49.5 | 44.5 | -    |      |
| PST 65-250/220            | 80x65    | 22                                      | 30   | 64.8                    | -    | -    | -    | -    | -    | -    | -    | -    | 64.7 | 62   | 60   | 58.5 | 53   | 50   | -    | -    |      |
| PST 65-250/300            | 80x65    | 30                                      | 40   | 80                      | -    | -    | -    | -    | -    | -    | -    | -    | 79.8 | 77.5 | 75.5 | 74.5 | 70   | 66   | 58   | -    |      |
| PST 65-250/370            | 80x65    | 37                                      | 50   | 92                      | -    | -    | -    | -    | -    | -    | -    | -    | 90.5 | 88.5 | 87   | 85   | 80.5 | 78   | 68   | -    |      |

**Pump operating range:**

The pump should be operated within the specified performance range (data specified in the data sheet).  
Never run the pump beyond the data sheet or nameplate.

- Measurements were carried out with clean water at 20° C of temperature and with a kinematic viscosity of  $\nu = 1 \text{ mm}^2/\text{s}$  (1 cSt)

| MODEL<br>MODELO<br>MODÈLE | DN<br>mm | Power<br>Potencia<br>Puissance<br>kw hp |     | Q=DELIVERY/CAUDAL/DÉBIT |      |       |      |      |      |      |      |      |      |      |      |      |      |      |   |   |
|---------------------------|----------|---|-----|-------------------------|------|-------|------|------|------|------|------|------|------|------|------|------|------|------|---|---|
|                           |          |   |     | us<br>gpm               | 0    | 264   | 396  | 529  | 634  | 793  | 881  | 925  | 969  | 1057 | 1233 | 1322 | 1586 | 1762 |   |   |
|                           |          |   |     | l/min                   | 0    | 1000  | 1500 | 2000 | 2400 | 3000 | 3333 | 3500 | 3667 | 4000 | 4667 | 5000 | 6000 | 6667 |   |   |
| PST 65-315/450            | 80x65    | 45                                      | 60  | 102                     | 98   | 94.5  | 90   | 83   | -    | -    | -    | -    | -    | -    | -    | -    | -    | -    | - | - |
| PST 65-315/550            | 80x65    | 55                                      | 75  | 122                     | 120  | 114.5 | 110  | 100  | 76   | -    | -    | -    | -    | -    | -    | -    | -    | -    | - | - |
| PST 65-315/750            | 80x65    | 75                                      | 100 | 141                     | 141  | 134.5 | 130  | 120  | 96   | 78   | 65.5 | -    | -    | -    | -    | -    | -    | -    | - | - |
| PST 65-315/900            | 80x65    | 90                                      | 125 | 151                     | 150  | 144.5 | 140  | 130  | 106  | 88   | 75.5 | -    | -    | -    | -    | -    | -    | -    | - | - |
| PST 80-125/40             | 100x80   | 4                                       | 5.5 | 17                      | 15   | 12.3  | 7.5  | -    | -    | -    | -    | -    | -    | -    | -    | -    | -    | -    | - | - |
| PST 80-125/55             | 100x80   | 5.5                                     | 7.5 | 21                      | 19.6 | 17.4  | 13.4 | 9.5  | -    | -    | -    | -    | -    | -    | -    | -    | -    | -    | - | - |
| PST 80-125/75             | 100x80   | 7.5                                     | 10  | 26                      | 24.8 | 23    | 19.5 | 16.5 | -    | -    | -    | -    | -    | -    | -    | -    | -    | -    | - | - |
| PST 80-160/110            | 100x80   | 11                                      | 15  | 28                      | 27   | 27.3  | 24.5 | 21.1 | 16   | -    | -    | -    | -    | -    | -    | -    | -    | -    | - | - |
| PST 80-160/150            | 100x80   | 15                                      | 20  | 34                      | 32.6 | 32.5  | 30.2 | 27   | 22.1 | 18.5 | 16.7 | -    | -    | -    | -    | -    | -    | -    | - | - |
| PST 80-160/185            | 100x80   | 18.5                                    | 25  | 39                      | 38.5 | 38    | 36.7 | 33.6 | 28.8 | 25.3 | 23.5 | -    | -    | -    | -    | -    | -    | -    | - | - |
| PST 80-160/220            | 100x80   | 22                                      | 30  | 44                      | 43.5 | 43    | 41.7 | 38.6 | 33.8 | 30.3 | 28.5 | -    | -    | -    | -    | -    | -    | -    | - | - |
| PST 80-200/220            | 100x80   | 22                                      | 30  | 48                      | 47.7 | 47.5  | 43.5 | 39.2 | 32.5 | 27.2 | 24.5 | -    | -    | -    | -    | -    | -    | -    | - | - |
| PST 80-200/300            | 100x80   | 30                                      | 40  | 60                      | 59.7 | 59.5  | 57   | 53.1 | 47   | 42.7 | 40.5 | -    | -    | -    | -    | -    | -    | -    | - | - |
| PST 80-250/370            | 100x80   | 37                                      | 50  | 71.5                    | 70.9 | 70.5  | 65.5 | 59.3 | 51   | 43.2 | 38.5 | -    | -    | -    | -    | -    | -    | -    | - | - |
| PST 80-250/450            | 100x80   | 45                                      | 60  | 88                      | 86.7 | 86    | 83.6 | 78.5 | 70.5 | 60   | 51   | -    | -    | -    |      |      |      |      |   |   |

DIMENSIONS AND WEIGHT/DIMENSIONES Y PESOS/DIMENSIONS ET POIDS

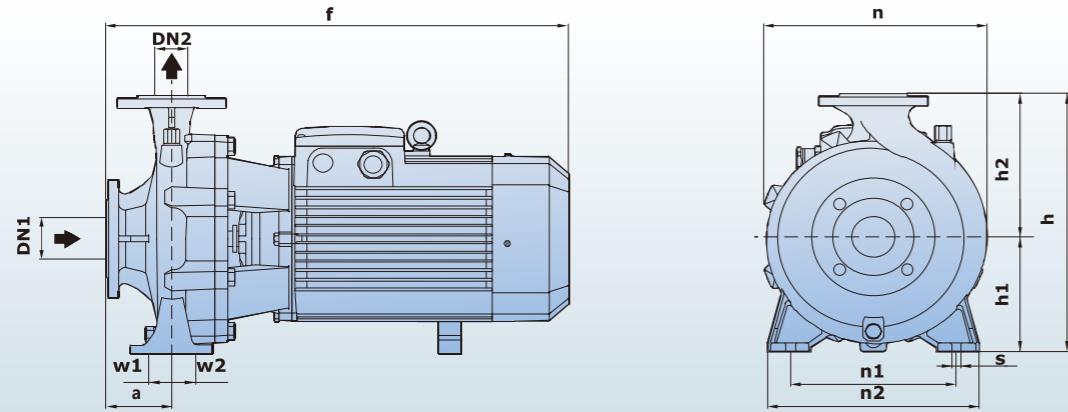

INDUSTRIAL PUMPS

| MODEL<br>MODELO<br>MODÈLE | DIMENSIONS/DIMENSIONES/DIMENSIONS mm |     |     |     |     |     |     |     |     |     |     |             |    | kg<br>3~ |     |     |             |     |             |     |     |     |     |    |             |    |       |
|---------------------------|--------------------------------------|-----|-----|-----|-----|-----|-----|-----|-----|-----|-----|-------------|----|----------|-----|-----|-------------|-----|-------------|-----|-----|-----|-----|----|-------------|----|-------|
|                           | DN1                                  | DN2 | a   | f   | h   | h1  | h2  | n   | n1  | n2  | w1  | w2          | s  |          |     |     |             |     |             |     |     |     |     |    |             |    |       |
| PST 32-125/7              | 50                                   | 32  | 80  | 435 | 255 | 114 | 141 | 202 | 140 | 190 | 35  | 35          | 15 | 24       |     |     |             |     |             |     |     |     |     |    |             |    |       |
| PST 32-125/11             |                                      |     |     |     |     |     |     |     |     |     |     |             |    | 25       |     |     |             |     |             |     |     |     |     |    |             |    |       |
| PST 32-160/15             |                                      |     |     |     |     |     |     |     |     |     |     |             |    | 34       |     |     |             |     |             |     |     |     |     |    |             |    |       |
| PST 32-160/22             |                                      |     | 83  | 435 | 295 | 133 | 162 | 245 | 190 | 245 | 35  | 35          | 15 | 39       |     |     |             |     |             |     |     |     |     |    |             |    |       |
| PST 32-160/30             |                                      |     |     |     |     |     |     |     |     |     |     |             |    | 50       |     |     |             |     |             |     |     |     |     |    |             |    |       |
| PST 32-200/30             |                                      |     | 82  | 490 | 342 | 161 | 181 | 265 | 190 | 240 | 35  | 35          | 15 | 52       |     |     |             |     |             |     |     |     |     |    |             |    |       |
| PST 32-200/40             |                                      |     |     |     |     |     |     |     |     |     |     |             |    | 53       |     |     |             |     |             |     |     |     |     |    |             |    |       |
| PST 32-250/55             |                                      |     | 88  | 590 | 405 | 186 | 219 | 333 | 250 | 328 | 49  | 49          | 16 | 66       |     |     |             |     |             |     |     |     |     |    |             |    |       |
| PST 32-250/75             |                                      |     |     |     |     |     |     |     |     |     |     |             |    | 73       |     |     |             |     |             |     |     |     |     |    |             |    |       |
| PST 32-250/92             |                                      |     |     |     |     |     |     |     |     |     |     |             |    | 80       |     |     |             |     |             |     |     |     |     |    |             |    |       |
| PST 32-250/110            |                                      |     |     |     |     |     |     |     |     |     |     |             |    | 95       |     |     |             |     |             |     |     |     |     |    |             |    |       |
| PST 32-250/150            |                                      |     |     |     |     |     |     |     |     |     |     |             |    | 125      |     |     |             |     |             |     |     |     |     |    |             |    |       |
| PST 32-250/55D-75D        |                                      |     |     |     |     |     |     |     |     |     |     |             |    | 73/80    |     |     |             |     |             |     |     |     |     |    |             |    |       |
| PST 40-125/11             |                                      |     | 40  | 37  | 82  | 440 | 260 | 116 | 144 | 220 | 160 | 212         | 37 | 37       | 14  | 27  |             |     |             |     |     |     |     |    |             |    |       |
| PST 40-125/15             | 29                                   |     |     |     |     |     |     |     |     |     |     |             |    |          |     |     |             |     |             |     |     |     |     |    |             |    |       |
| PST 40-125/22             | 34                                   |     |     |     |     |     |     |     |     |     |     |             |    |          |     |     |             |     |             |     |     |     |     |    |             |    |       |
| PST 40-160/30             | 80                                   | 490 |     |     |     |     |     |     |     |     |     |             |    |          |     | 305 | 135         | 170 | 250         | 190 | 241 | 37  | 37  | 14 | 48          |    |       |
| PST 40-160/40             |                                      |     |     |     |     |     |     |     |     |     |     |             |    |          |     |     |             |     |             |     |     |     |     |    | 50          |    |       |
| PST 40-200/55-75          |                                      |     |     |     |     |     |     |     |     |     |     |             |    |          |     |     |             |     |             |     |     |     |     |    | 66/73       |    |       |
| PST 40-250/92             | 94                                   | 712 |     |     |     |     |     |     |     |     |     |             |    |          |     | 415 | 186         | 229 | 327         | 250 | 327 | 49  | 49  | 16 | 100         |    |       |
| PST 40-250/110            |                                      |     |     |     |     |     |     |     |     |     |     |             |    |          |     |     |             |     |             |     |     |     |     |    | 116         |    |       |
| PST 40-250/150            |                                      |     |     |     |     |     |     |     |     |     |     |             |    |          |     |     |             |     |             |     |     |     |     |    | 146         |    |       |
| PST 40-250/185            |                                      |     |     |     |     |     |     |     |     |     |     |             |    |          |     |     |             |     |             |     |     |     |     |    | 155         |    |       |
| PST 50-125/22             | 50                                   | 37  | 102 | 525 | 305 | 135 | 170 | 263 | 190 | 245 | 37  | 37          | 15 | 41       |     |     |             |     |             |     |     |     |     |    |             |    |       |
| PST 50-125/30             |                                      |     |     |     |     |     |     |     |     |     |     |             |    | 50       |     |     |             |     |             |     |     |     |     |    |             |    |       |
| PST 50-125/40             |                                      |     |     |     |     |     |     |     |     |     |     |             |    | 52       |     |     |             |     |             |     |     |     |     |    |             |    |       |
| PST 50-160/55-75          |                                      |     |     |     |     |     |     |     |     |     |     |             |    | 110      | 560 | 348 | 164         | 193 | 270         | 212 | 262 | 37  | 37  | 15 | 64/71       |    |       |
| PST 50-200/92             |                                      |     |     |     |     |     |     |     |     |     |     |             |    |          |     |     |             |     |             |     |     |     |     |    | 90          |    |       |
| PST 50-200/110            |                                      |     |     |     |     |     |     |     |     |     |     |             |    | 104      | 722 | 392 | 186         | 206 | 307         | 232 | 310 | 37  | 37  | 15 | 106         |    |       |
| PST 50-200/150            |                                      |     |     |     |     |     |     |     |     |     |     |             |    |          |     |     |             |     |             |     |     |     |     |    | 145         |    |       |
| PST 50-250/150-185-220    |                                      |     |     |     |     |     |     |     |     |     |     |             |    | 102      | 720 | 416 | 186         | 230 | 330         | 250 | 327 | 37  | 37  | 15 | 148/153/183 |    |       |
| PST 65-125/40             |                                      |     |     |     |     |     |     |     |     |     |     |             |    | 80       | 65  | 104 | 580         | 345 | 162         | 193 | 275 | 212 | 280 | 49 | 49          | 16 | 56    |
| PST 65-125/55-75          |                                      |     |     |     |     |     |     |     |     |     |     |             |    |          |     |     |             |     |             |     |     |     |     |    |             |    | 68/74 |
| PST 65-160/92             | 110                                  | 730 | 425 | 186 | 239 | 330 | 232 | 309 | 49  | 49  | 16  | 90          |    |          |     |     |             |     |             |     |     |     |     |    |             |    |       |
| PST 65-160/110            |                                      |     |     |     |     |     |     |     |     |     |     | 106         |    |          |     |     |             |     |             |     |     |     |     |    |             |    |       |
| PST 65-160/150            | 111                                  | 740 | 425 | 186 | 239 | 330 | 232 | 309 | 49  | 49  | 16  | 134         |    |          |     |     |             |     |             |     |     |     |     |    |             |    |       |
| PST 65-200/150-185-220    |                                      |     |     |     |     |     |     |     |     |     |     | 140/145/185 |    |          |     |     |             |     |             |     |     |     |     |    |             |    |       |
| PST 80-125/40             | 100                                  | 80  | 117 | 750 | 357 | 163 | 194 | 330 | 212 | 280 | 55  | 55          | 16 | 56       |     |     |             |     |             |     |     |     |     |    |             |    |       |
| PST 80-125/55-75          |                                      |     |     |     |     |     |     |     |     |     |     |             |    | 68/74    |     |     |             |     |             |     |     |     |     |    |             |    |       |
| PST 80-160/110            |                                      |     | 88  | 750 | 435 | 186 | 250 | 330 | 255 | 332 |     |             |    | 55       | 55  | 16  | 113         |     |             |     |     |     |     |    |             |    |       |
| PST 80-160/150-185-220    |                                      |     |     |     |     |     |     |     |     |     |     |             |    |          |     |     | 143/150/183 |     |             |     |     |     |     |    |             |    |       |
| PST 100-160/150-185-220   |                                      |     | 125 | 100 | 130 | 765 | 435 | 186 | 250 | 345 |     |             |    | 262      | 340 | 55  | 55          | 16  | 143/150/183 |     |     |     |     |    |             |    |       |

Type of construction IEC IM B35 standard motor with sleeve shaft, Rated Output P2=22kW, 30kW, 37kW

DIMENSIONS AND WEIGHT/DIMENSIONES Y PESOS/DIMENSIONS ET POIDS

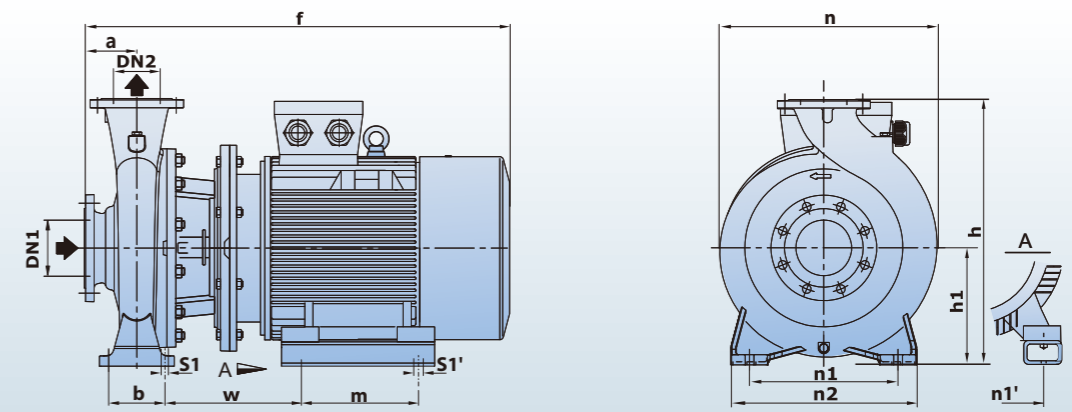

INDUSTRIAL PUMPS

| MODEL<br>MODELO<br>MODÈLE | DIMENSIONS/DIMENSIONES/DIMENSIONS mm |     |     |      |     |     |     |     |     |     |     |     |     |    |     |         | kg<br>3~ |
|---------------------------|--------------------------------------|-----|-----|------|-----|-----|-----|-----|-----|-----|-----|-----|-----|----|-----|---------|----------|
|                           | DN1                                  | DN2 | a   | f    | h   | h1  | n   | n1  | n1' | n2  | b   | w   | m   | s1 | s1' |         |          |
| PST 65-250/220            | 80                                   | 65  | 116 | 870  | 420 | 180 | 369 | 280 | 279 | 360 | 120 | 237 | 241 | 18 | 15  | 214     |          |
| PST 65-250/300            | 80                                   | 65  | 116 | 990  | 420 | 180 | 369 | 280 | 318 | 360 | 120 | 278 | 305 | 18 | 18  | 265     |          |
| PST 65-250/370            | 80                                   | 65  | 116 | 990  | 420 | 180 | 369 | 280 | 318 | 360 | 120 | 278 | 305 | 18 | 18  | 285     |          |
| PST 65-315/450            | 80                                   | 65  | 125 | 1069 | 505 | 225 | 440 | 280 | 356 | 360 | 120 | 324 | 311 | 18 | 18  | 371     |          |
| PST 65-315/550            | 80                                   | 65  | 125 | 1160 | 505 | 225 | 440 | 280 | 406 | 360 | 120 | 373 | 349 | 18 | 24  | 450     |          |
| PST 65-315/750            | 80                                   | 65  | 125 | 1232 | 505 | 225 | 440 | 280 | 457 | 360 | 120 | 395 | 368 | 18 | 24  | 582     |          |
| PST 65-315/900            | 80                                   | 65  | 125 | 1283 | 505 | 225 | 440 | 280 | 457 | 360 | 120 | 395 | 419 | 18 | 24  | 617     |          |
| PST 80-200/220            | 100                                  | 80  | 125 | 880  | 460 | 250 | 360 | 280 | 279 | 345 | 95  | 251 | 241 | 14 | 15  | 211     |          |
| PST 80-200/300            | 100                                  | 80  | 125 | 950  | 460 | 250 | 360 | 280 | 318 | 345 | 95  | 242 | 305 | 14 | 18  | 262     |          |
| PST 80-250/370            | 100                                  | 80  | 125 | 950  | 535 | 250 | 410 | 315 | 318 | 400 | 120 | 229 | 305 | 18 | 18  | 289     |          |
| PST 80-250/450            | 100                                  | 80  | 125 | 980  | 535 | 250 | 410 | 315 | 356 | 400 | 120 | 235 | 311 | 18 | 18  | 362     |          |
| PST 80-250/550            | 100                                  | 80  | 125 | 1160 | 535 | 250 | 410 | 315 | 406 | 400 | 120 | 373 | 349 | 18 | 24  | 441     |          |
| PST 80-315/450            | 100                                  | 80  | 125 | 1069 | 565 | 250 | 452 | 315 | 356 | 400 | 120 | 324 | 311 | 18 | 18  | 381     |          |
| PST 80-315/550            | 100                                  | 80  | 125 | 1160 | 565 | 250 | 452 | 315 | 406 | 400 | 120 | 373 | 349 | 18 | 24  | 460     |          |
| PST 80-315/750            | 100                                  | 80  | 125 | 1232 | 565 | 250 | 452 | 315 | 457 | 400 | 120 | 395 | 368 | 18 | 24  | 592     |          |
| PST 80-315/900            | 100                                  | 80  | 125 | 1283 | 565 | 250 | 452 | 315 | 457 | 400 | 120 | 395 | 419 | 18 | 24  | 627     |          |
| PST 100-200/220           | 125                                  | 100 | 125 | 910  | 530 | 225 | 422 | 280 | 279 | 360 | 120 | 268 | 241 | 18 | 15  | 216     |          |
| PST 100-200/300           | 125                                  | 100 | 125 | 1025 | 530 | 225 | 422 | 280 | 318 | 360 | 120 | 304 | 305 | 18 | 18  | 267     |          |
| PST 100-200/370           | 125                                  | 100 | 125 | 1025 | 530 | 225 | 422 | 280 | 318 | 360 | 120 | 304 | 305 | 18 | 18  | 287     |          |
| PST 100-250/450           | 125                                  | 100 | 140 | 1000 | 580 | 250 | 450 | 315 | 356 | 400 | 120 | 240 | 311 | 18 | 18  | 366     |          |
| PST 100-250/550           | 125                                  | 100 | 140 | 1180 | 580 | 250 | 450 | 315 | 406 | 400 | 120 | 378 | 349 | 18 | 24  | 445     |          |
| PST 100-250/750           | 125                                  | 100 | 140 | 1250 | 580 | 250 | 450 | 315 | 457 | 400 | 120 | 398 | 368 | 18 | 24  | 577     |          |
| PST 100-250/900           | 125                                  | 100 | 140 | 1300 | 580 | 250 | 422 | 315 | 457 | 400 | 120 | 397 | 419 | 18 | 24  | 612     |          |
| PST 100-315/750           | 125                                  | 100 | 140 | 1262 | 625 | 250 | 480 | 315 | 457 | 400 | 120 | 410 | 368 | 19 | 24  | 591     |          |
| PST 100-315/900           | 125                                  | 100 | 140 | 1313 | 625 | 250 | 480 | 315 | 457 | 400 | 120 | 410 | 419 | 19 | 24  | 626     |          |
| PST 100-315/1100          | 125                                  | 100 | 140 | 1474 | 625 | 250 | 480 | 315 | 508 | 400 | 120 | 436 | 406 | 19 | 28  | 972     |          |
| PST 100-315/1320          | 125                                  | 100 | 140 | 1584 | 625 | 250 | 480 | 315 | 508 | 400 | 120 | 436 | 457 | 19 | 28  | 1087    |          |
| PST 100-315/1600          | 125                                  | 100 | 140 | 1584 | 625 | 250 | 480 | 315 | 508 | 400 | 120 | 436 | 508 | 19 | 28  | 1125    |          |
| PST 125-200/450           | 150                                  | 125 | 140 | 1099 | 565 | 250 | 422 | 315 | 356 | 400 | 120 | 339 | 311 | 19 | 18  | 378     |          |
| PST 125-200/550           | 150                                  | 125 | 140 | 1190 | 565 | 250 | 422 | 315 | 406 | 400 | 120 | 388 | 349 | 19 | 24  | 457     |          |
| PST 125-200/750           | 150                                  | 125 | 140 | 1262 | 565 | 250 | 422 | 315 | 457 | 400 | 120 | 410 | 368 | 19 | 24  | 589     |          |
| PST 125-250/550           | 150                                  | 125 | 140 | 1190 | 605 | 250 | 500 | 315 | 406 | 400 | 120 | 388 | 349 | 19 | 24  | 457     |          |
| PST 125-250/750           | 150                                  | 125 | 140 | 1262 | 605 | 250 | 500 | 315 | 457 | 400 | 120 | 410 | 368 | 19 | 24  | 589     |          |
| PST 125-250/900           | 150                                  | 125 | 140 | 1313 | 605 | 250 | 500 | 315 | 457 | 400 | 120 | 410 | 419 | 19 | 24  | 624     |          |
| PST4 65-250/30            | 80                                   | 65  | 116 | 606  | 420 | 180 | 369 | 280 | 160 | 360 | 120 | 147 | 140 | 18 | 12  | 71      |          |
| PST4 65-250/40            | 80                                   | 65  | 116 | 594  | 420 | 180 | 369 | 280 | 190 | 360 | 120 | 154 | 140 | 18 | 12  | 87      |          |
| PST4 65-250/55            | 80                                   | 65  | 116 | 638  | 420 | 180 | 369 | 280 | 216 | 360 | 120 | 193 | 140 | 18 | 12  | 98      |          |
| PST4 65-315/40            | 80                                   | 65  | 125 | 644  | 505 | 225 | 440 | 280 | 190 | 360 | 120 | 195 | 140 | 18 | 12  | 101     |          |
| PST4 65-315/55-75         | 80                                   | 65  | 125 | 688  | 505 | 225 | 440 | 280 | 216 | 360 | 120 | 234 | 140 | 18 | 12  | 112/130 |          |
| PST4 65-315/110-150       | 80                                   | 65  | 125 | 858  | 505 | 225 | 440 | 280 | 254 | 360 | 120 | 283 | 210 | 18 | 15  | 163/185 |          |
| PST4 80-200/30            | 100                                  | 80  | 125 | 606  | 460 | 250 | 360 | 280 | 160 | 345 | 95  | 151 | 140 | 14 | 12  | 68      |          |
| PST4 80-200/40            | 100                                  | 80  | 125 | 594  | 460 | 250 | 360 | 280 | 190 | 345 | 95  | 158 | 140 | 14 | 12  | 84      |          |

### 32-125

2900rpm

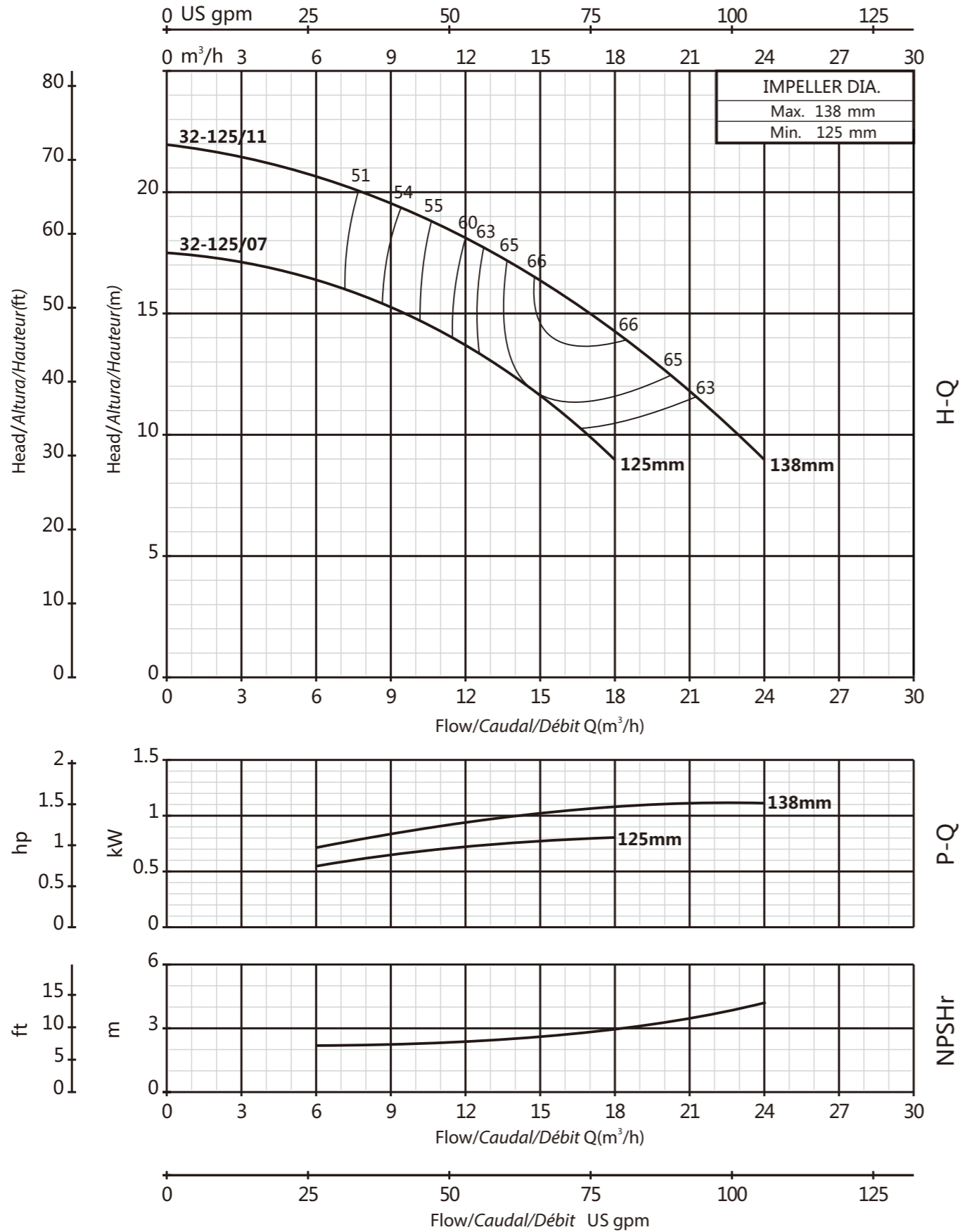

PERFORMANCE CURVE/CURVA DE RENDIMIENTO/COURBE DE PERFORMANCE

### 32-160

2900rpm

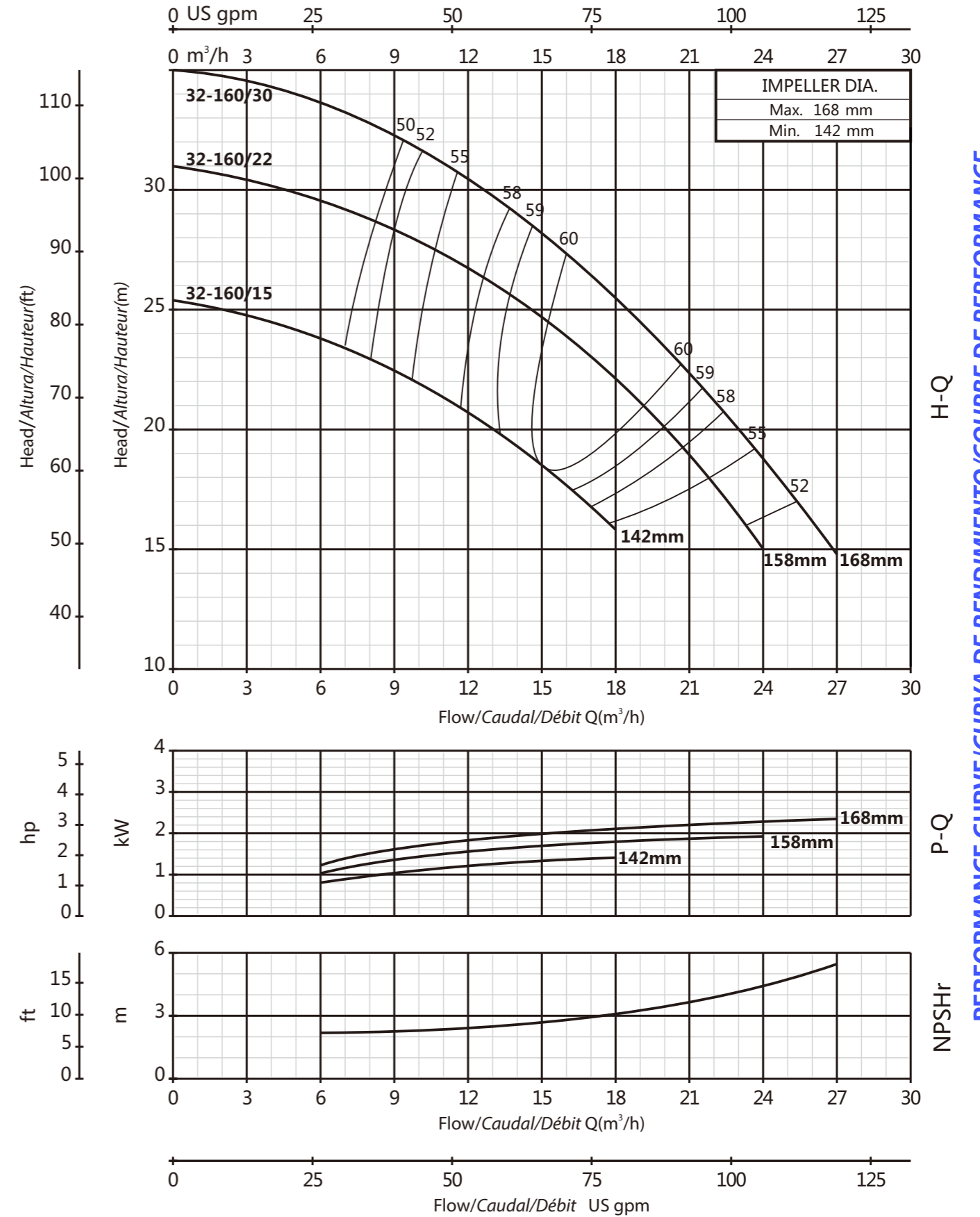

PERFORMANCE CURVE/CURVA DE RENDIMIENTO/COURBE DE PERFORMANCE

### 32-200

2900rpm

PERFORMANCE CURVE/CURVA DE RENDIMIENTO/COURBE DE PERFORMANCE

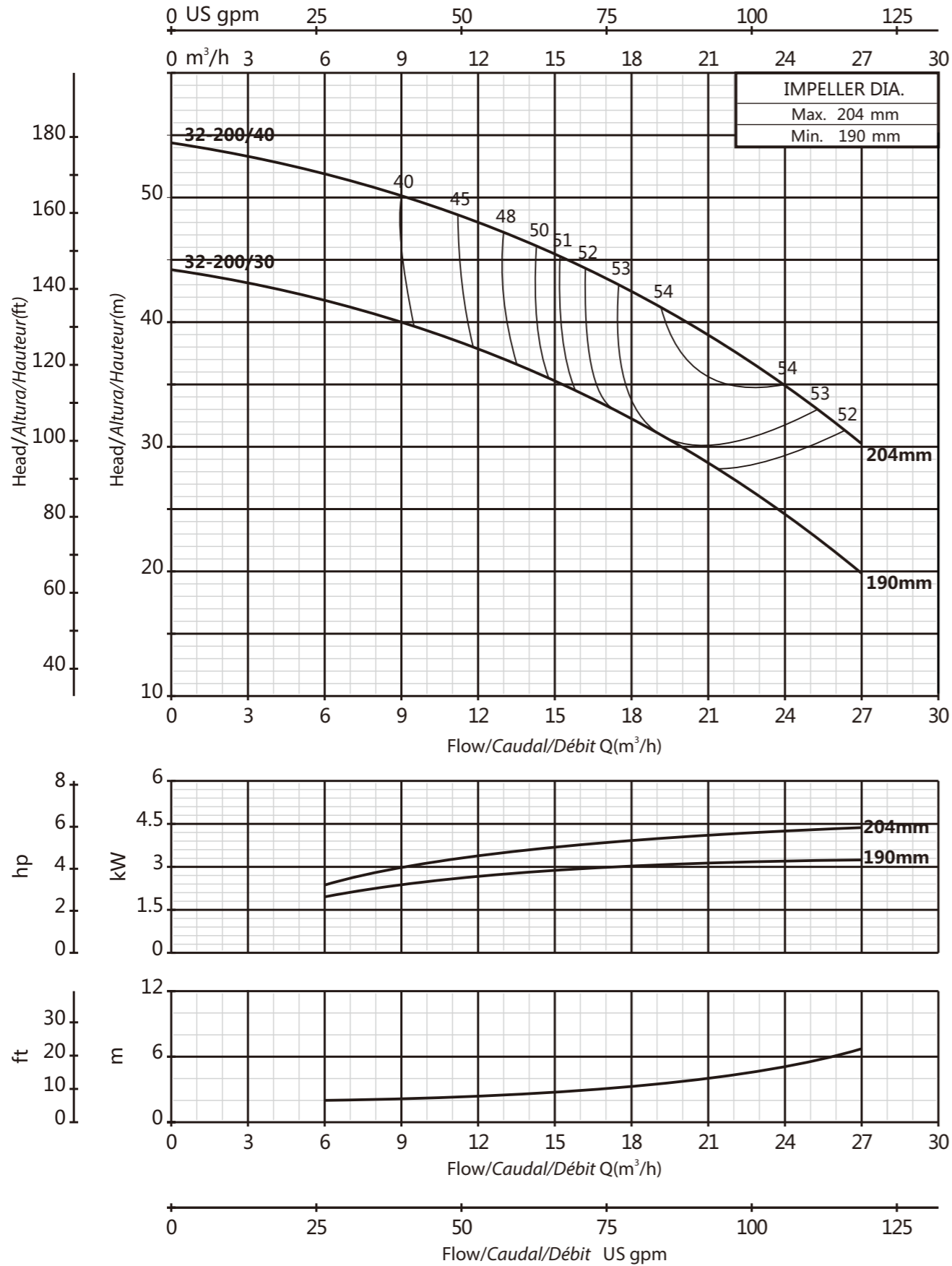

### 32-250

2900rpm

PERFORMANCE CURVE/CURVA DE RENDIMIENTO/COURBE DE PERFORMANCE

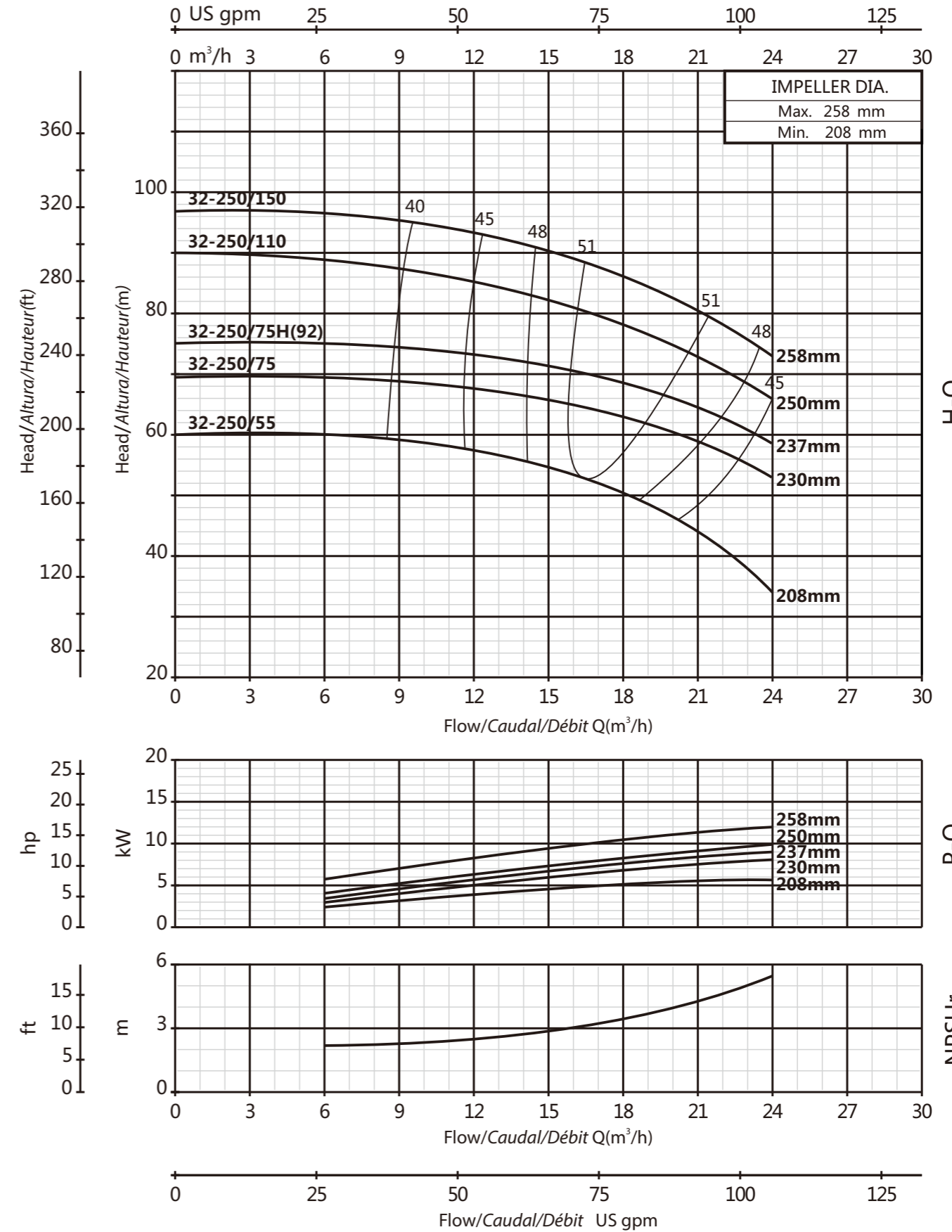

**32-250D**

2900rpm

PERFORMANCE CURVE/CURVA DE RENDIMIENTO/COURBE DE PERFORMANCE

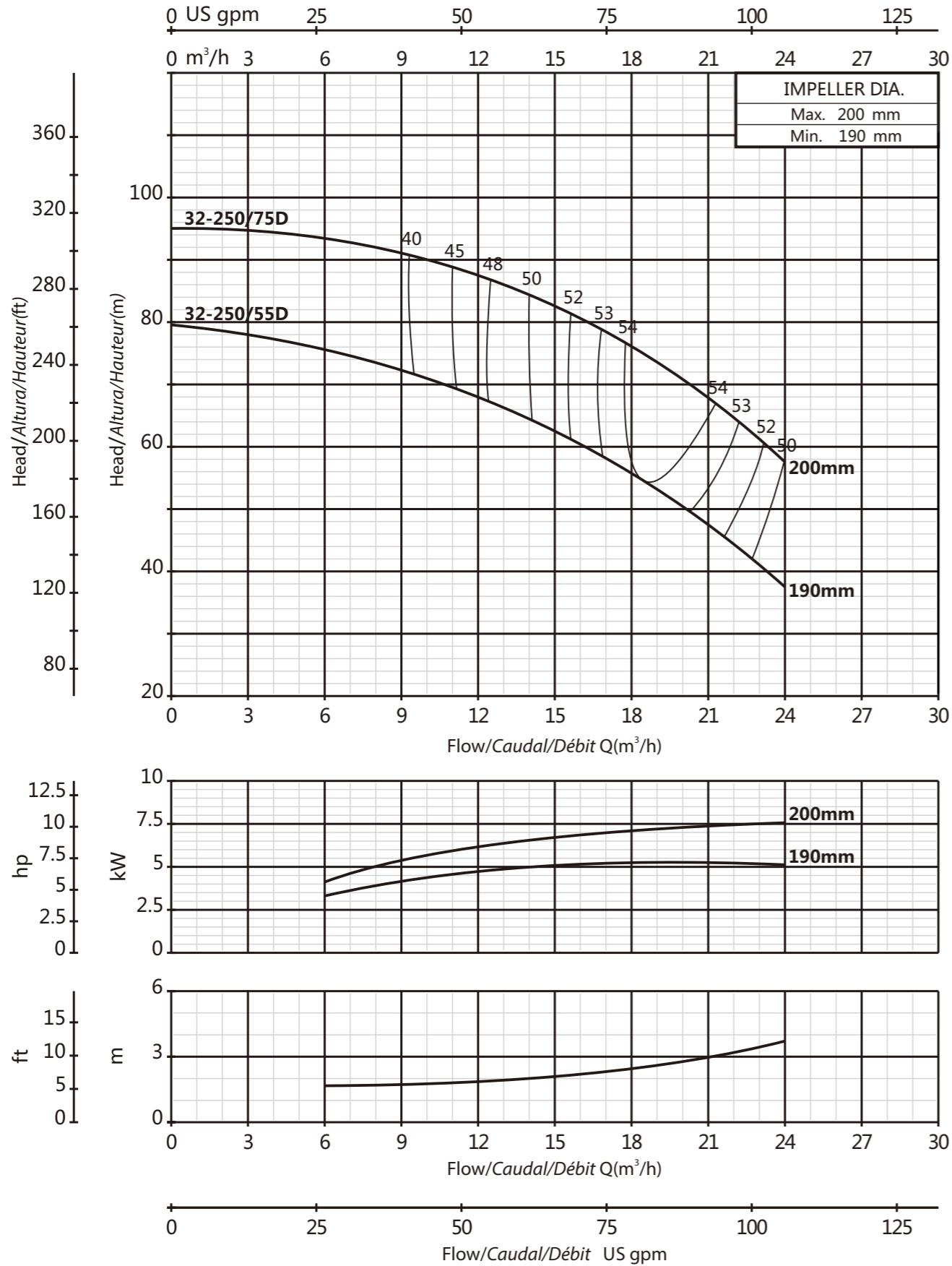

**40-125**

2900rpm

PERFORMANCE CURVE/CURVA DE RENDIMIENTO/COURBE DE PERFORMANCE

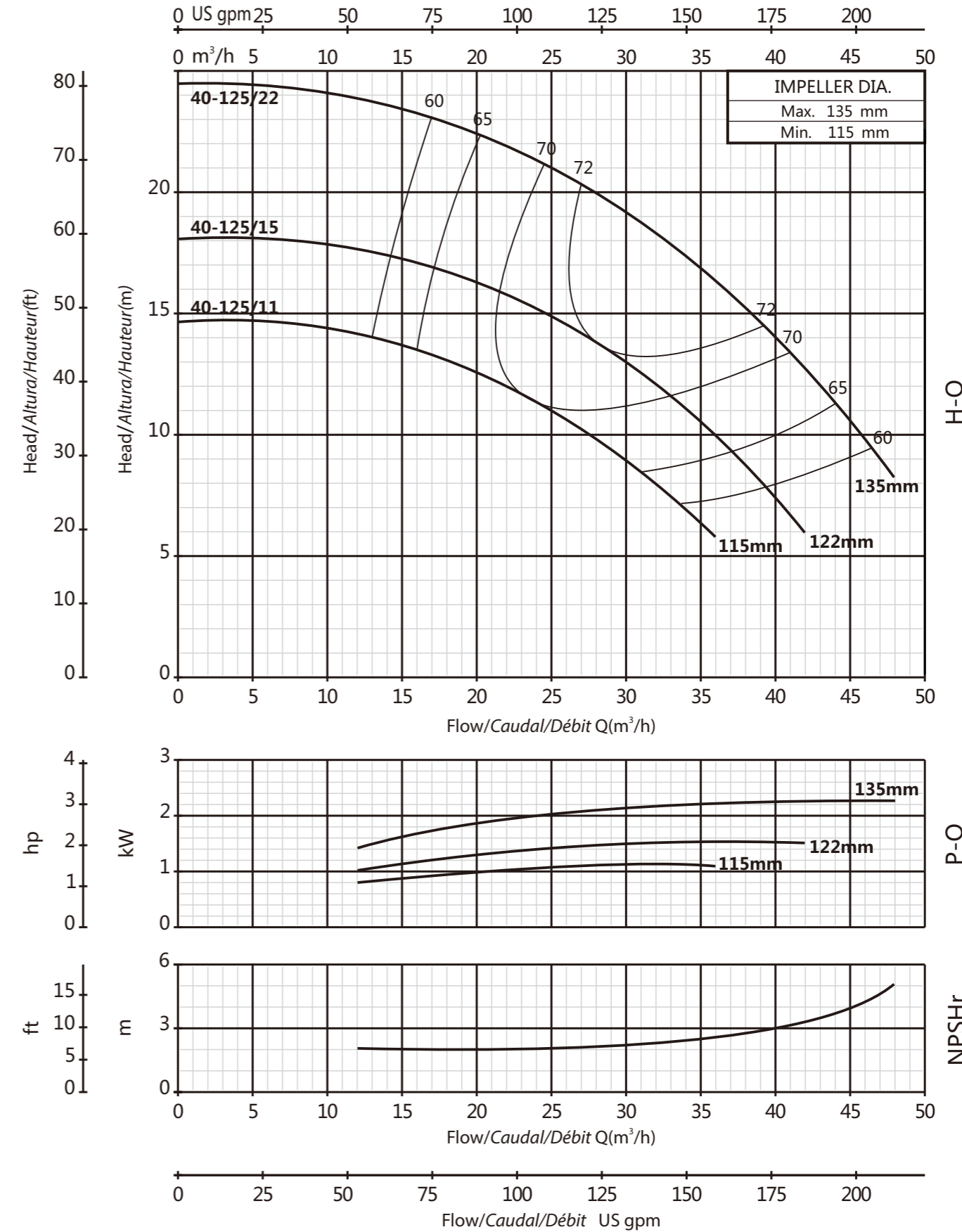

**40-160**

2900rpm

PERFORMANCE CURVE/CURVA DE RENDIMIENTO/COURBE DE PERFORMANCE

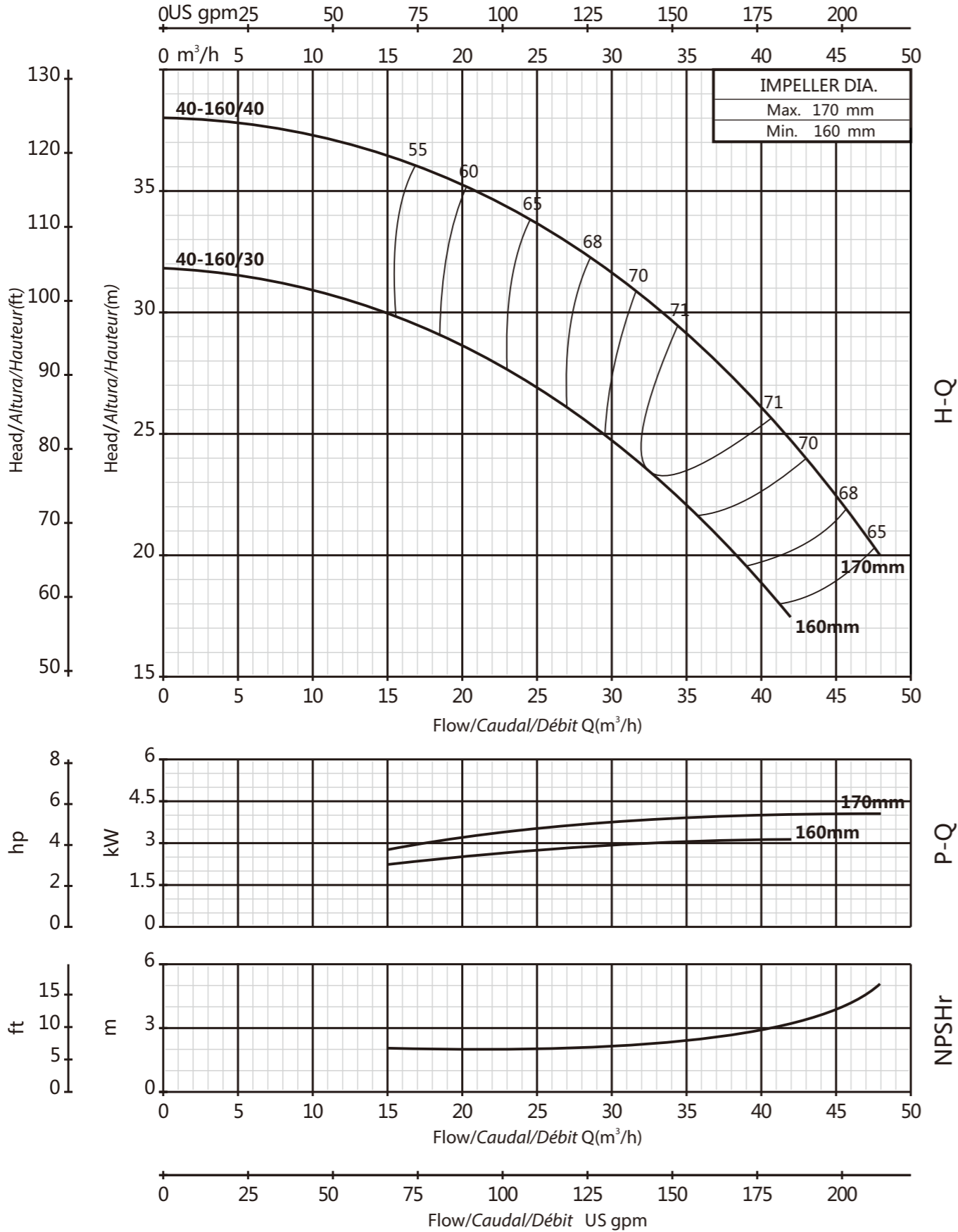

**40-200**

2900rpm

PERFORMANCE CURVE/CURVA DE RENDIMIENTO/COURBE DE PERFORMANCE

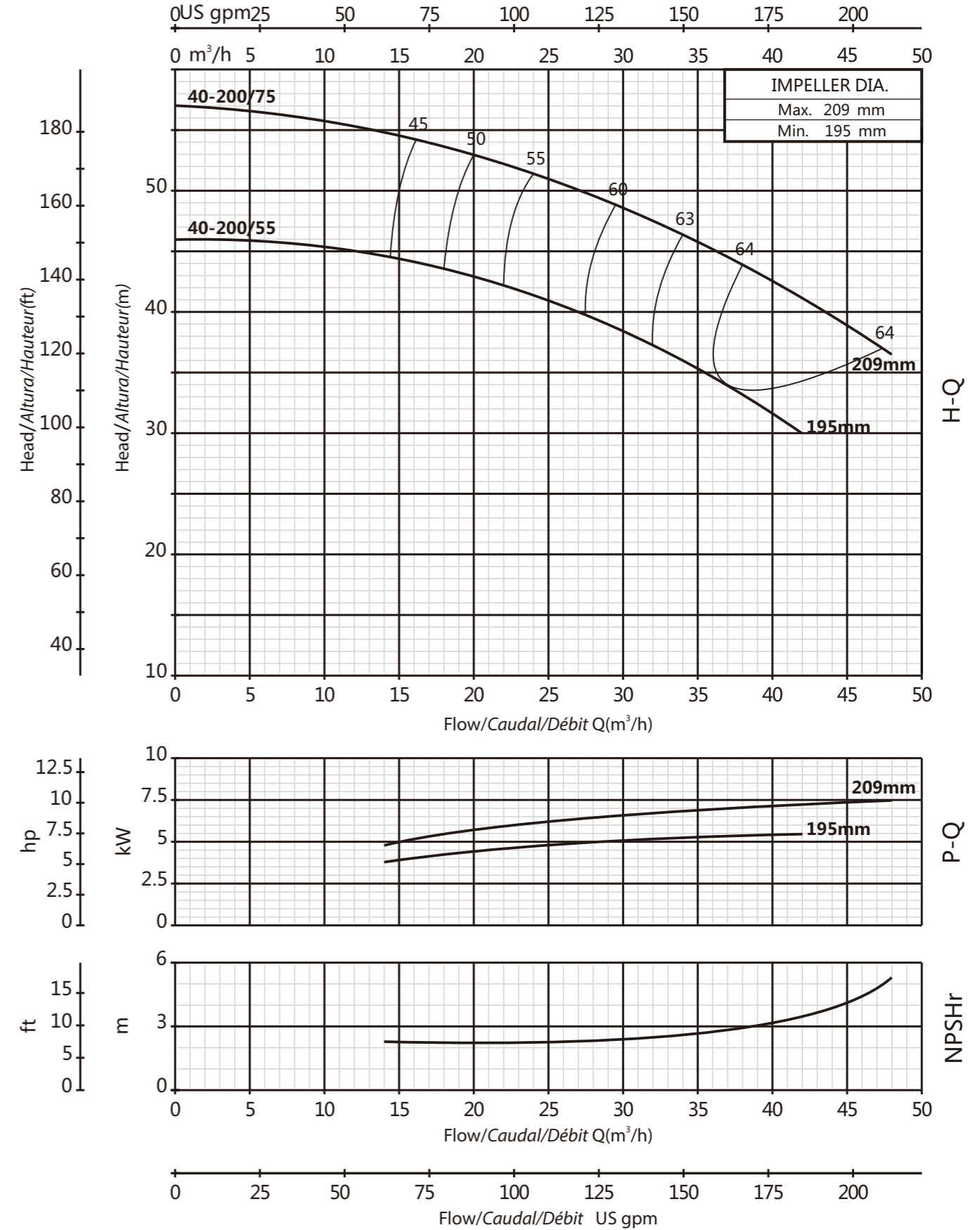

### 40-250

2900rpm

PERFORMANCE CURVE/CURVA DE RENDIMIENTO/COURBE DE PERFORMANCE

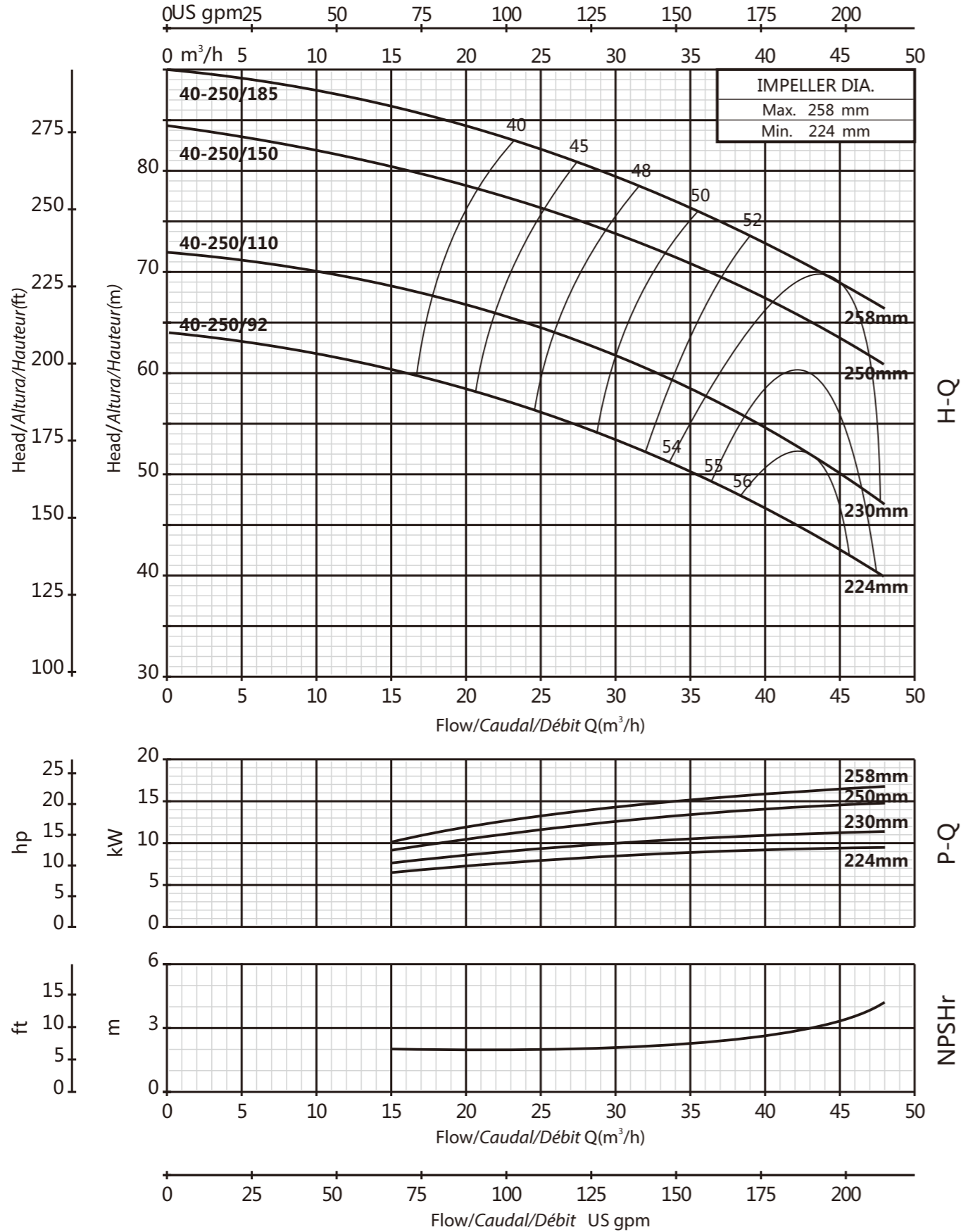

### 40-315

2900rpm

PERFORMANCE CURVE/CURVA DE RENDIMIENTO/COURBE DE PERFORMANCE

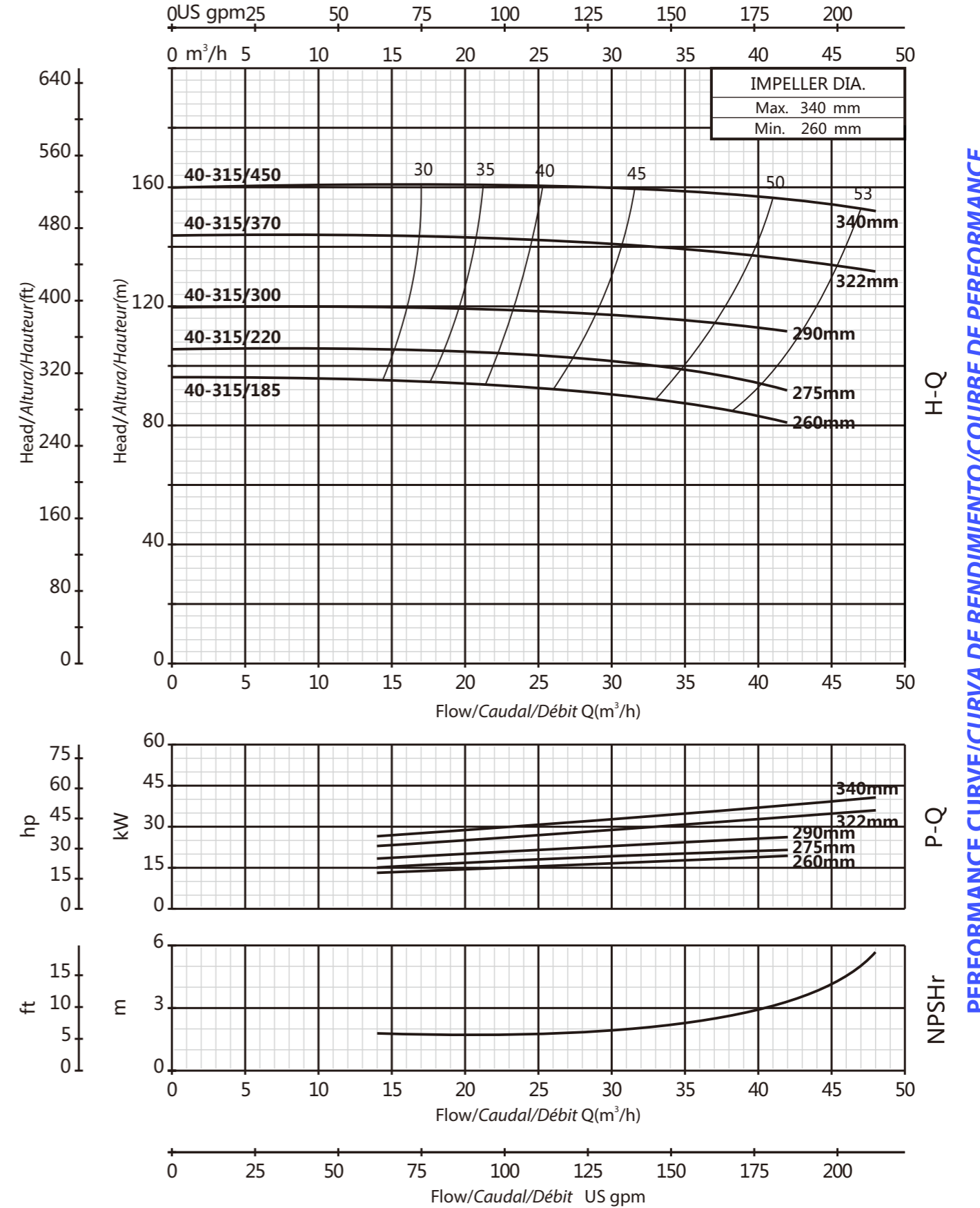

### 50-125

2900rpm

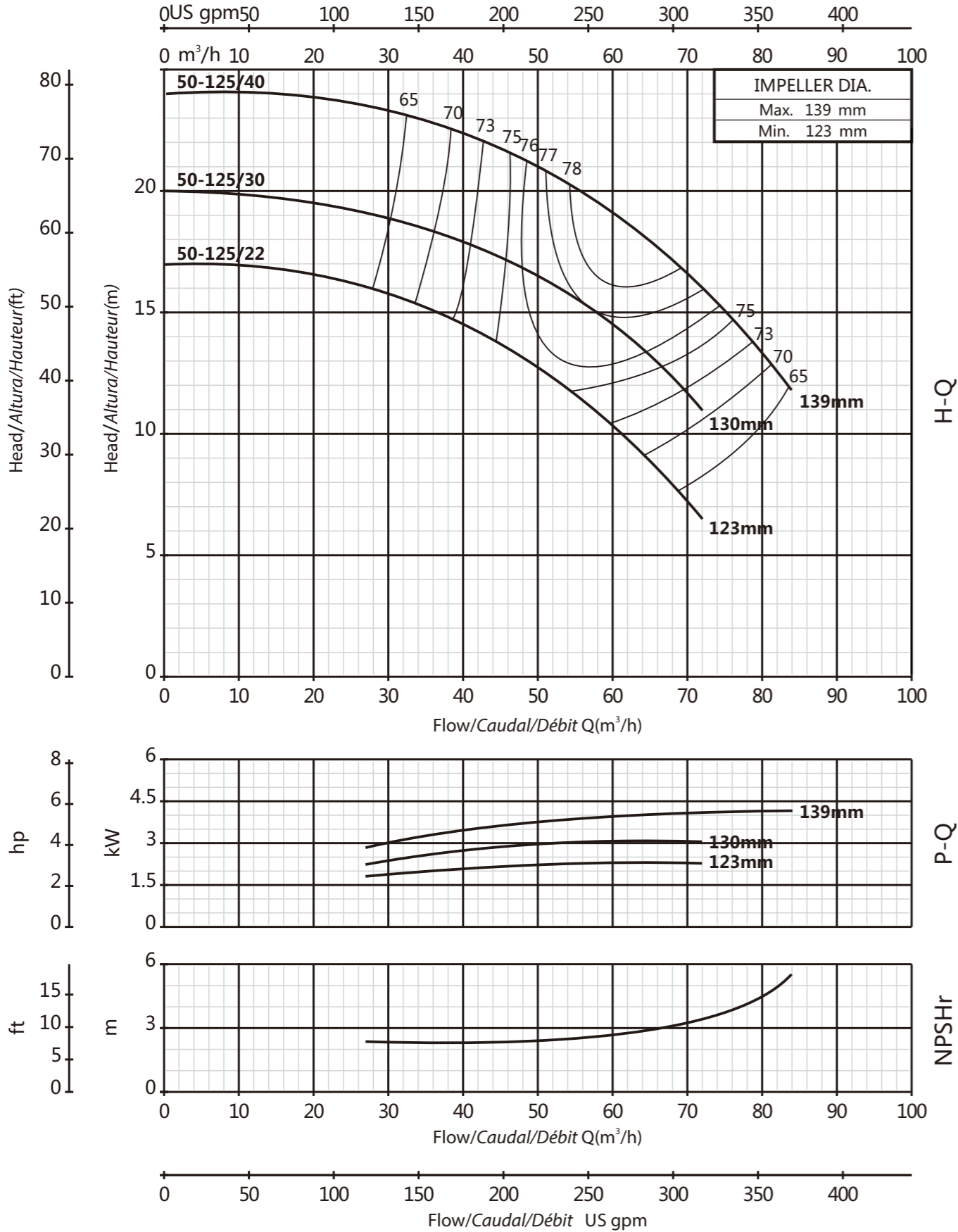

PERFORMANCE CURVE/CURVA DE RENDIMIENTO/COURBE DE PERFORMANCE

### 50-160

2900rpm

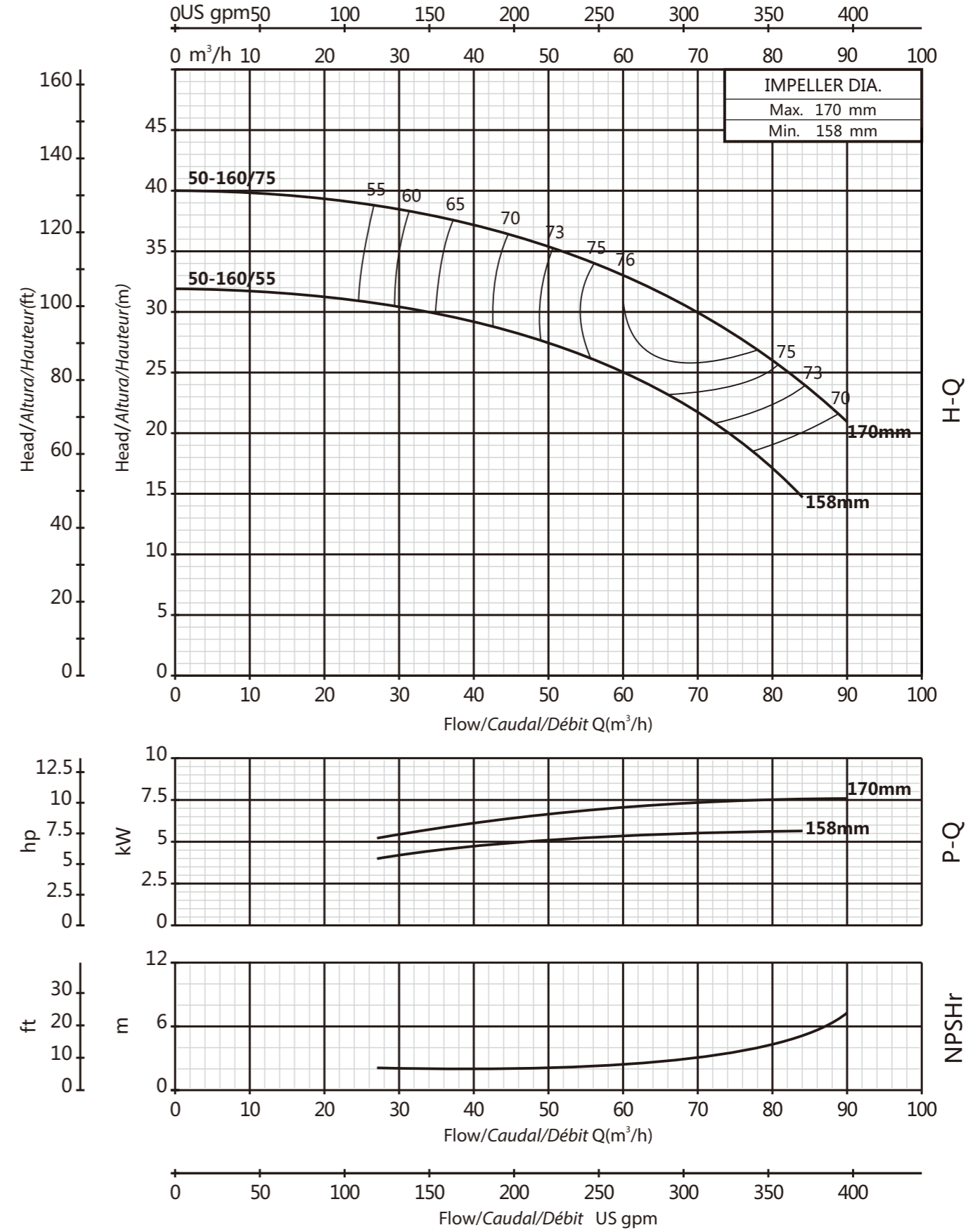

PERFORMANCE CURVE/CURVA DE RENDIMIENTO/COURBE DE PERFORMANCE

### 50-200

2900rpm

PERFORMANCE CURVE/CURVA DE RENDIMIENTO/COURBE DE PERFORMANCE

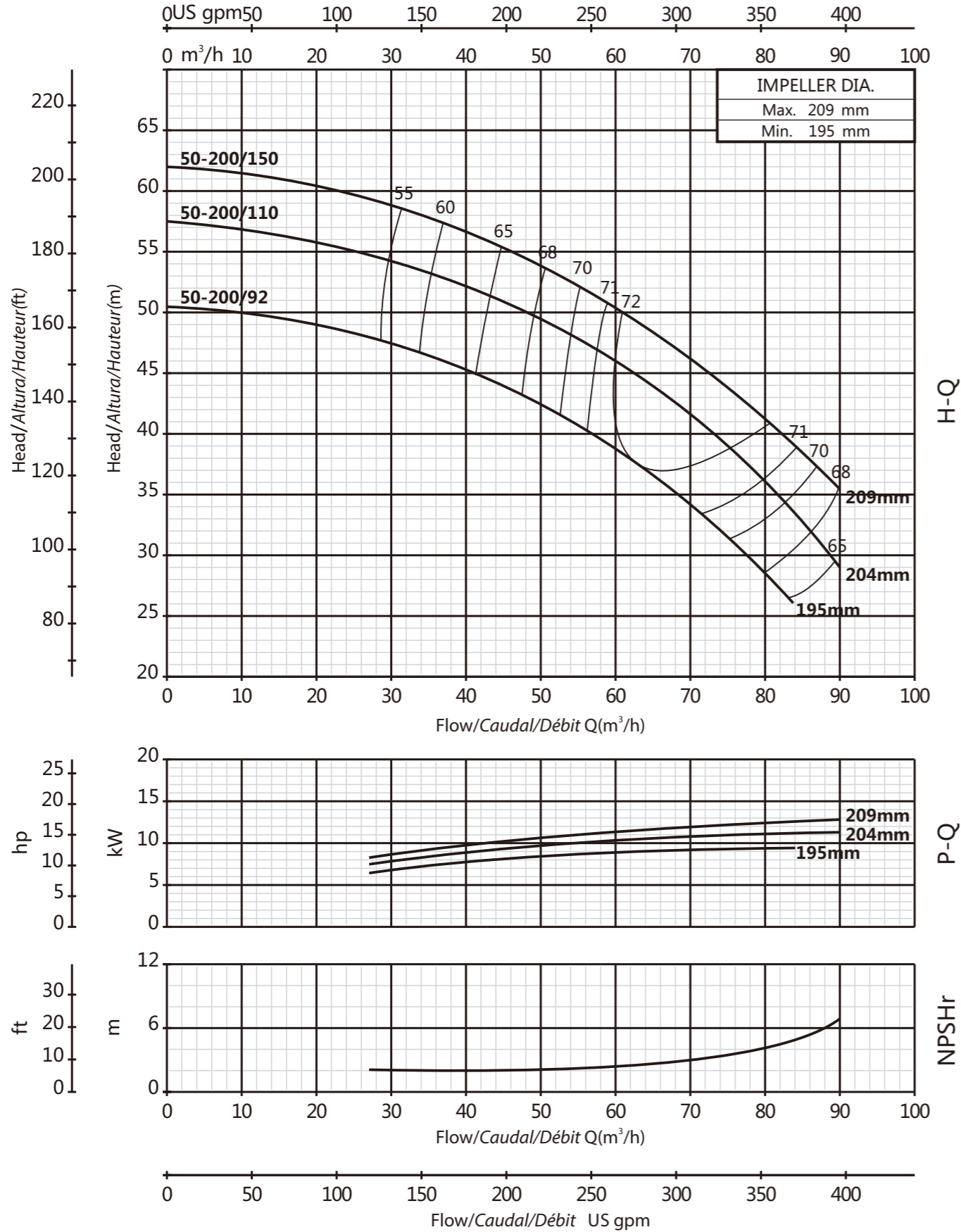

### 50-250

2900rpm

PERFORMANCE CURVE/CURVA DE RENDIMIENTO/COURBE DE PERFORMANCE

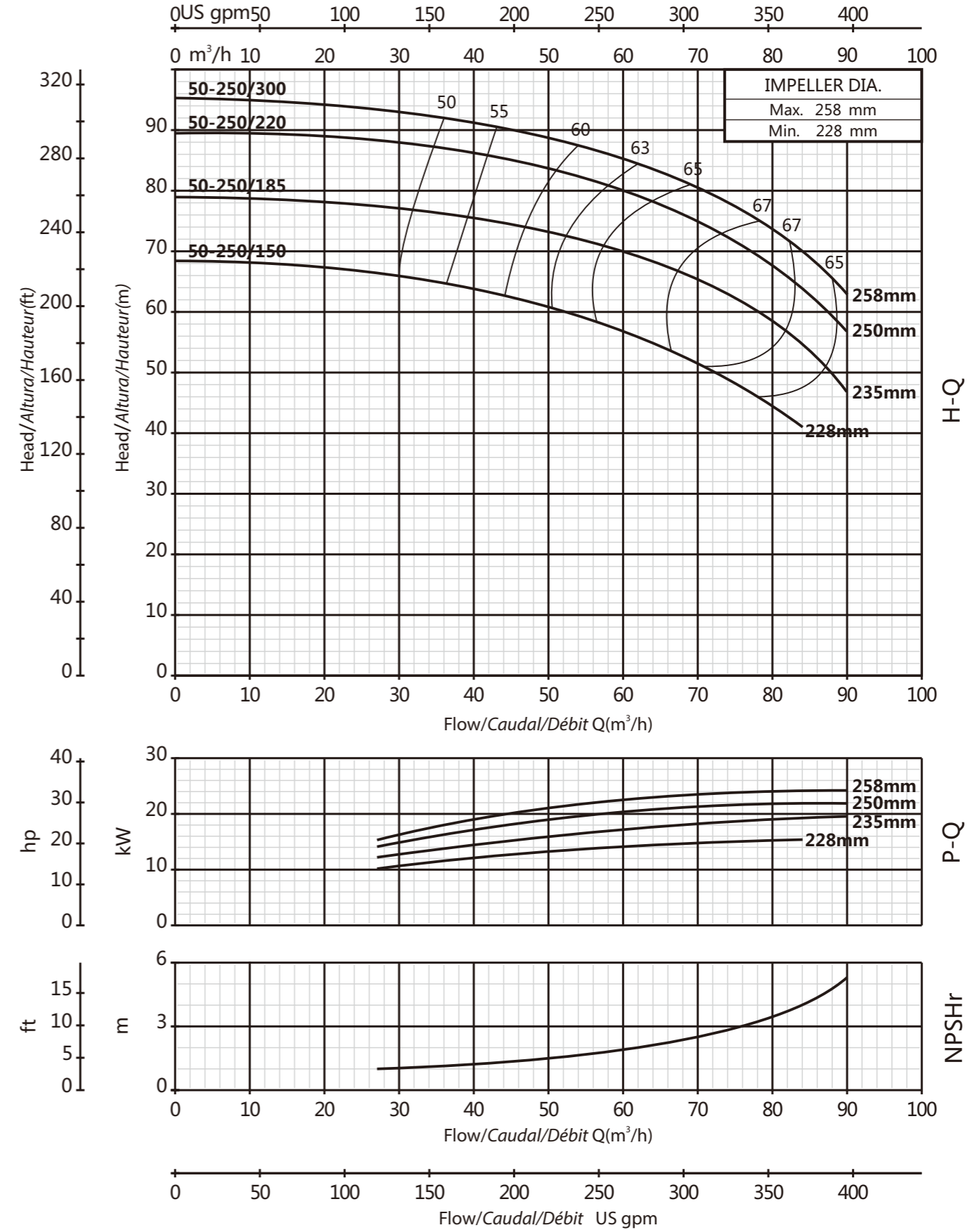

### 50-315

2900rpm

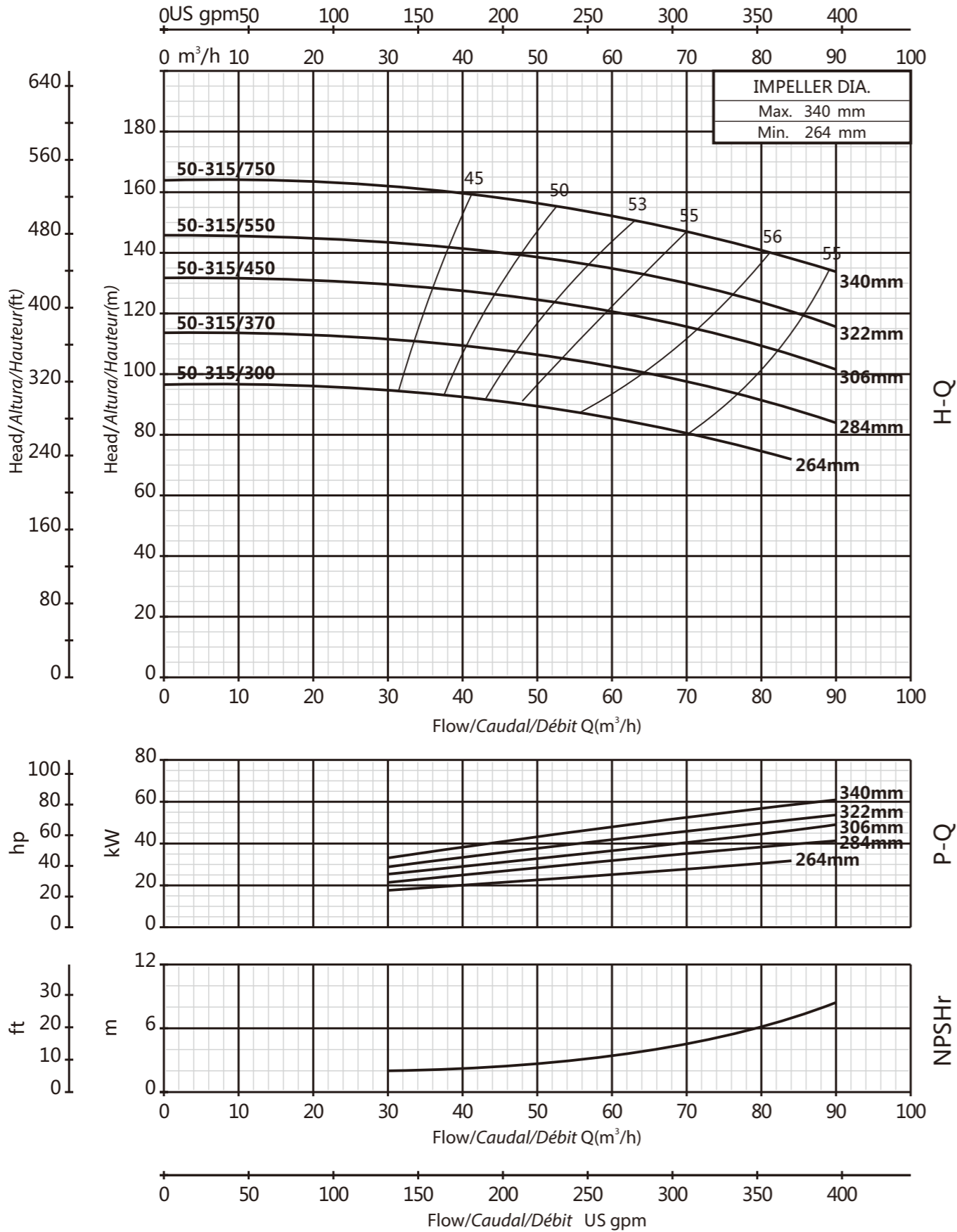

PERFORMANCE CURVE/CURVA DE RENDIMIENTO/COURBE DE PERFORMANCE

### 65-125

2900rpm

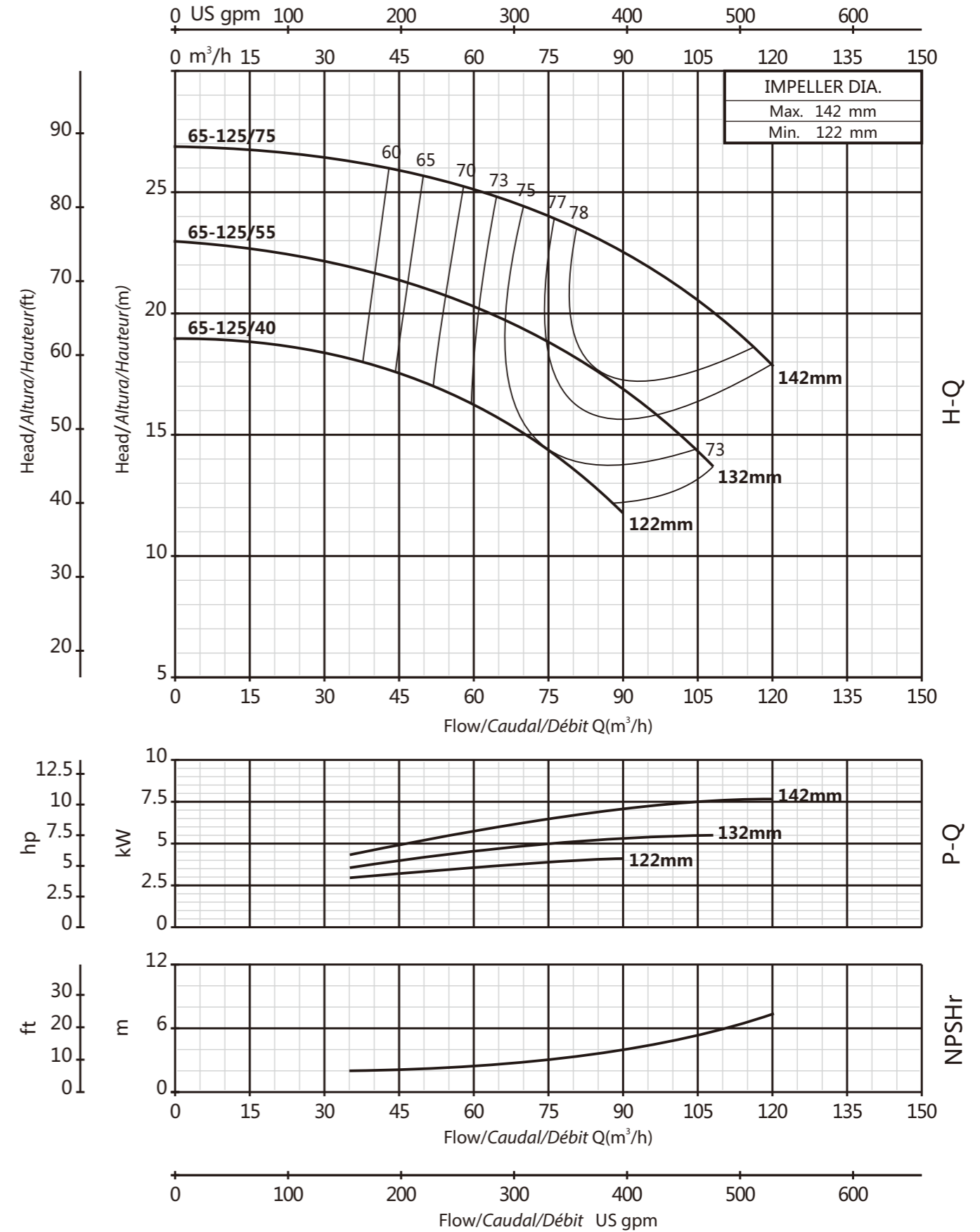

PERFORMANCE CURVE/CURVA DE RENDIMIENTO/COURBE DE PERFORMANCE

### 65-160

2900rpm

PERFORMANCE CURVE/CURVA DE RENDIMIENTO/COURBE DE PERFORMANCE

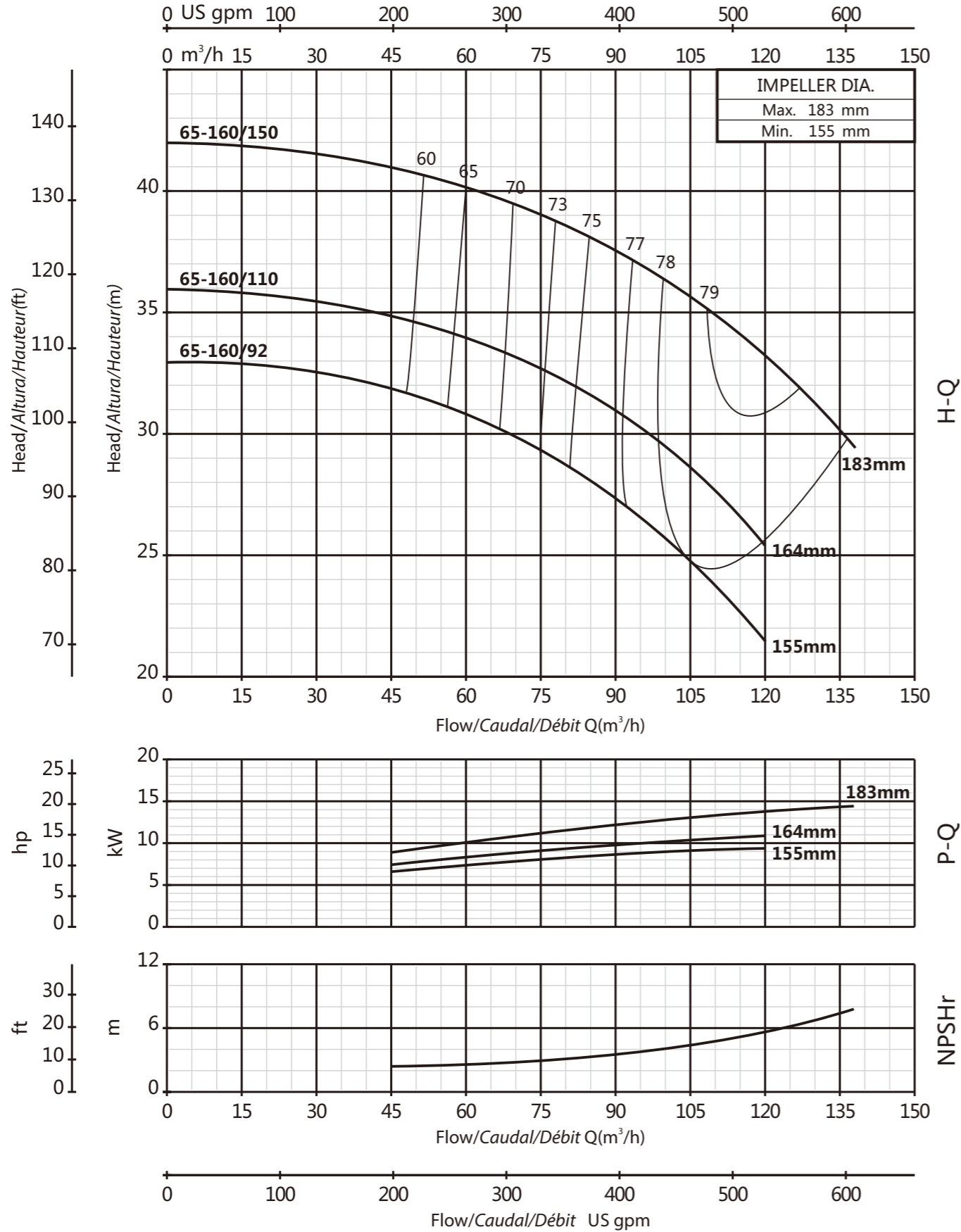

### 65-200

2900rpm

PERFORMANCE CURVE/CURVA DE RENDIMIENTO/COURBE DE PERFORMANCE

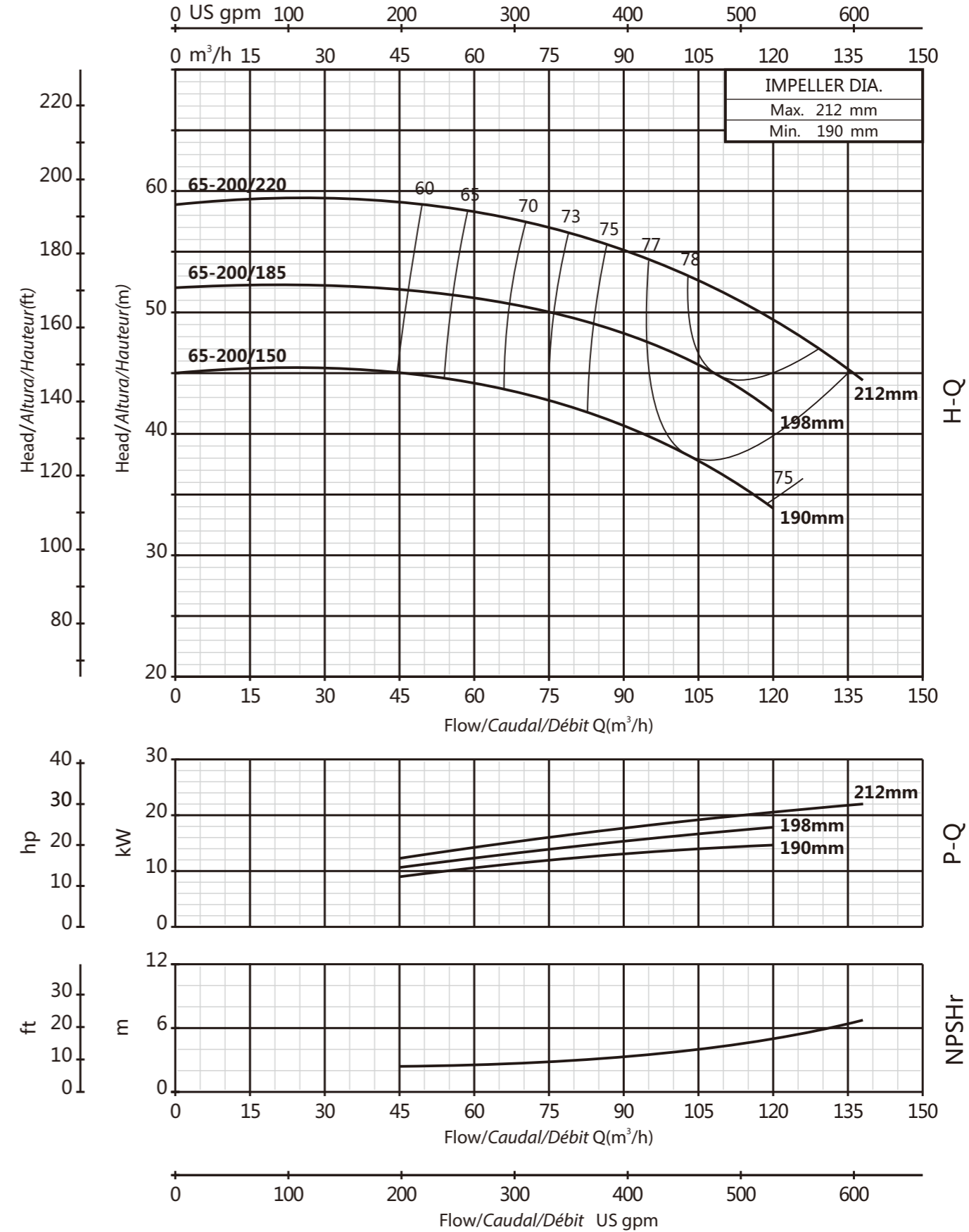

**65-250**

2900rpm

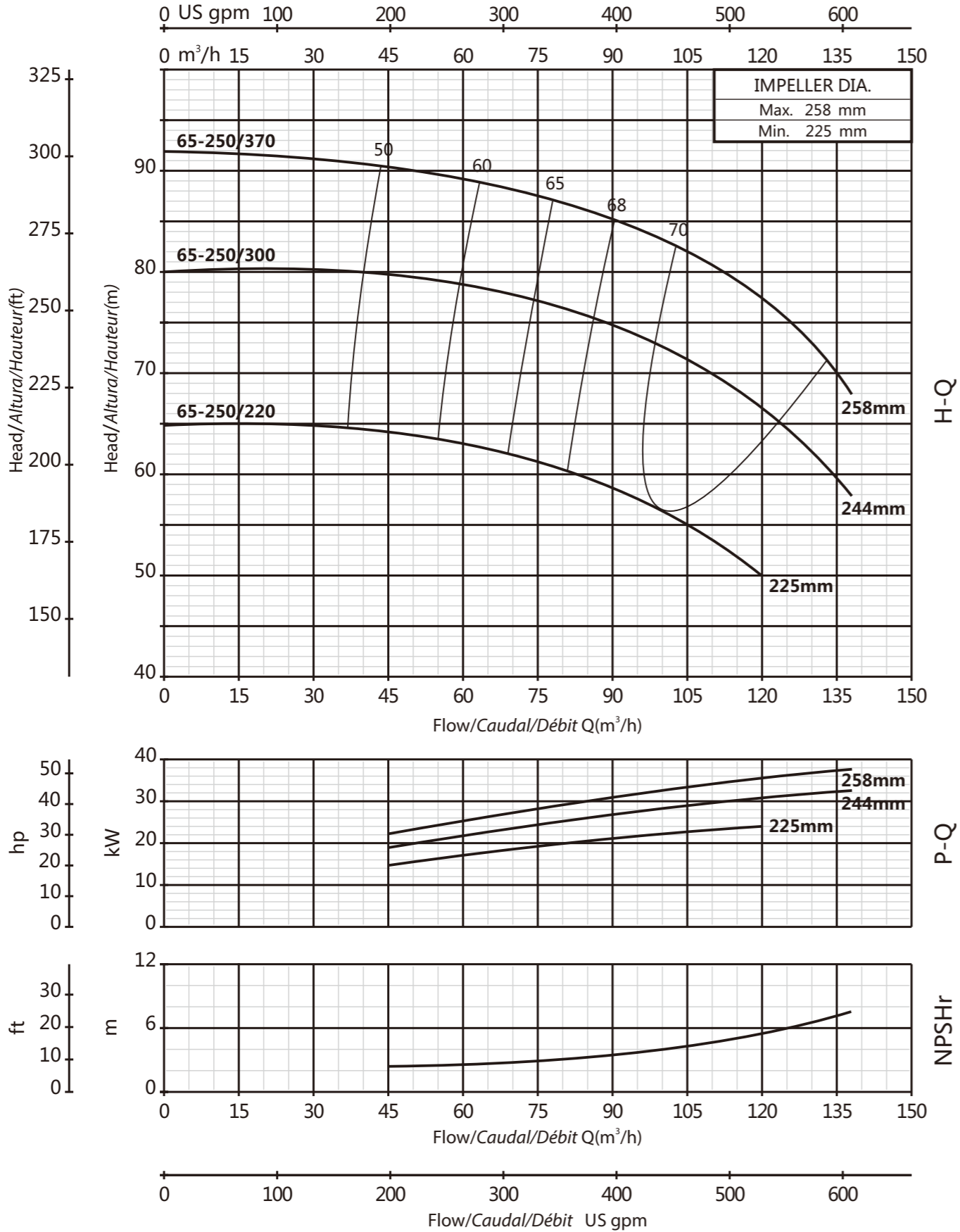

PERFORMANCE CURVE/CURVA DE RENDIMIENTO/COURBE DE PERFORMANCE

**65-315**

2900rpm

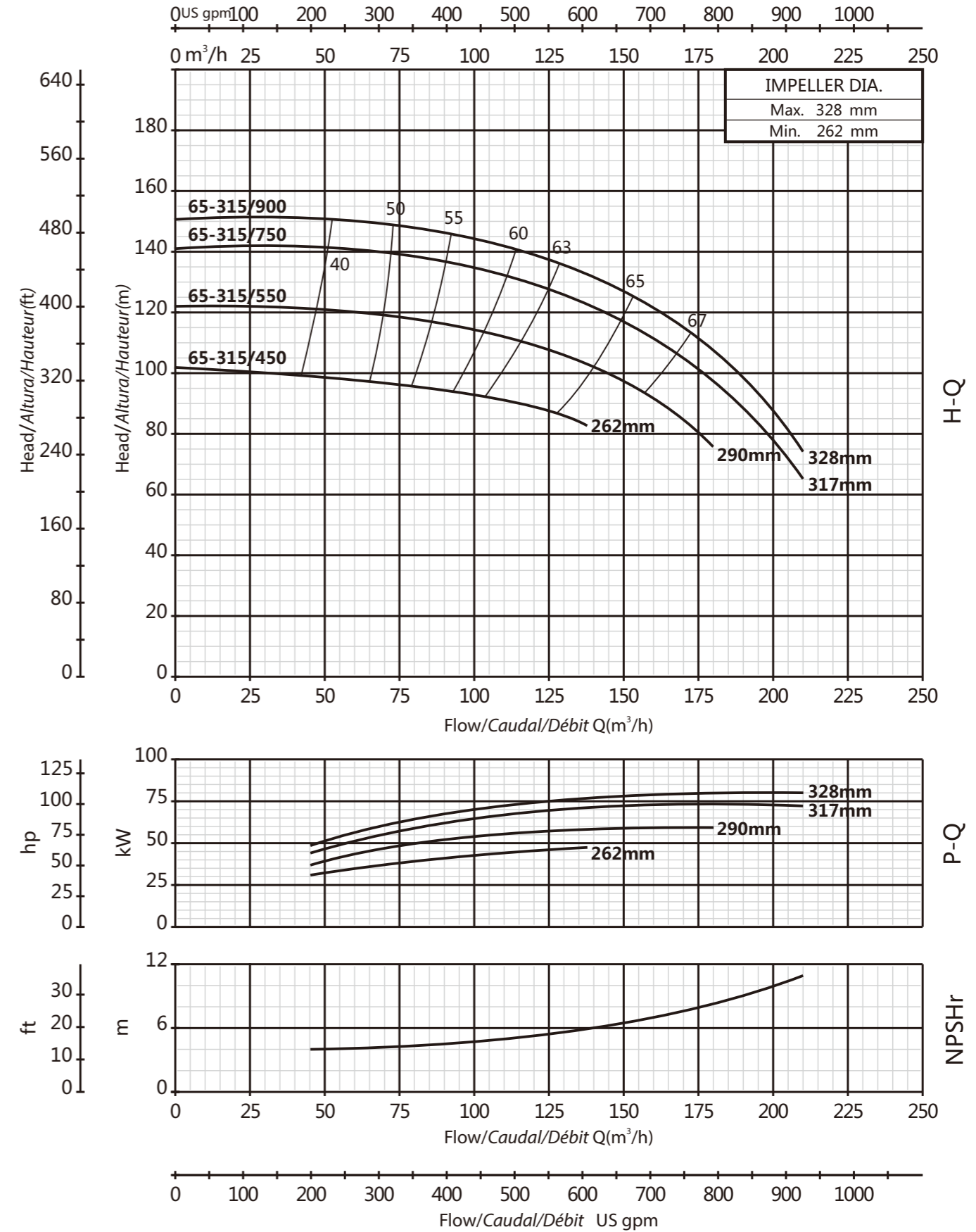

PERFORMANCE CURVE/CURVA DE RENDIMIENTO/COURBE DE PERFORMANCE

**80-125**

2900rpm

PERFORMANCE CURVE/CURVA DE RENDIMIENTO/COURBE DE PERFORMANCE

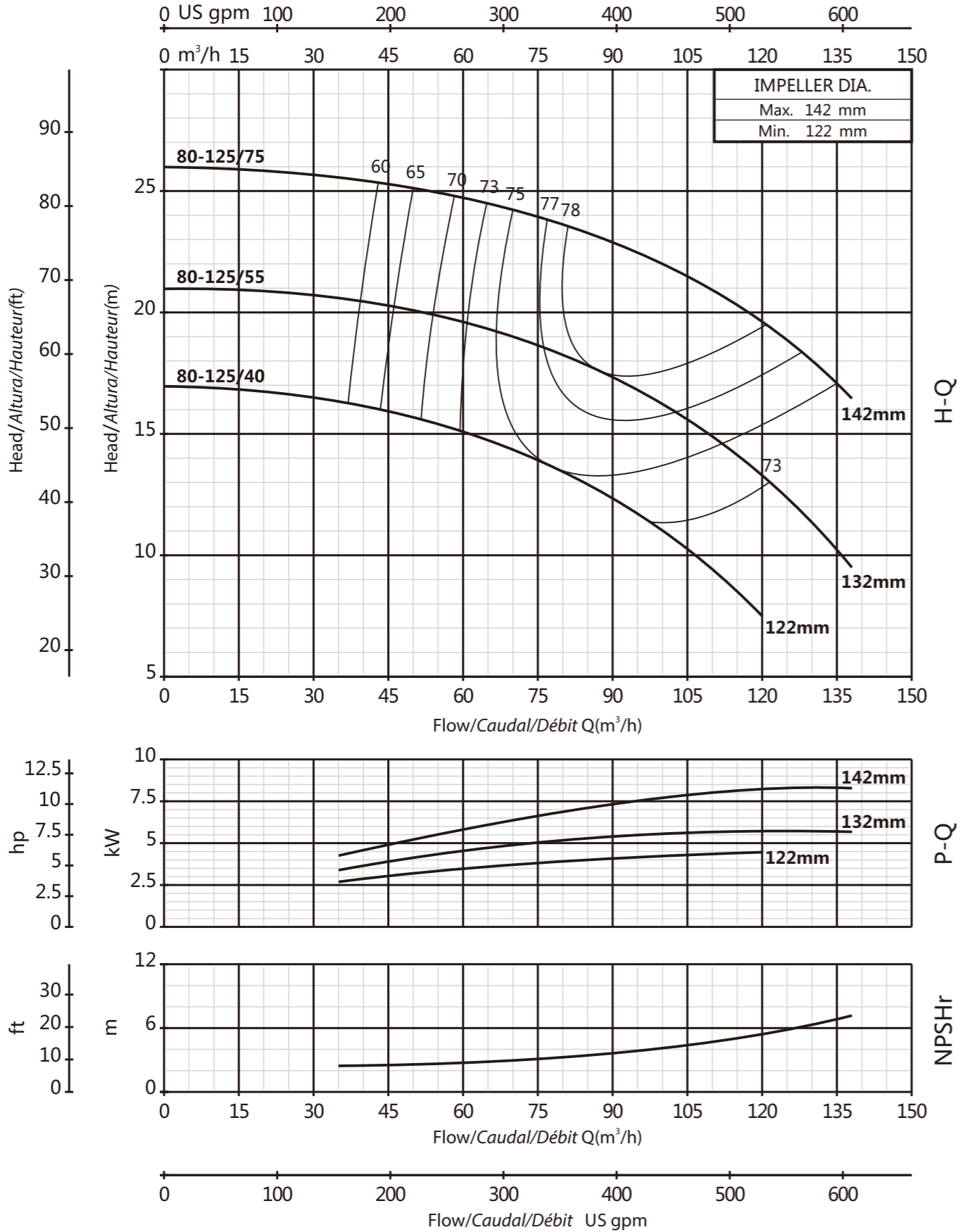

**80-160**

2900rpm

PERFORMANCE CURVE/CURVA DE RENDIMIENTO/COURBE DE PERFORMANCE

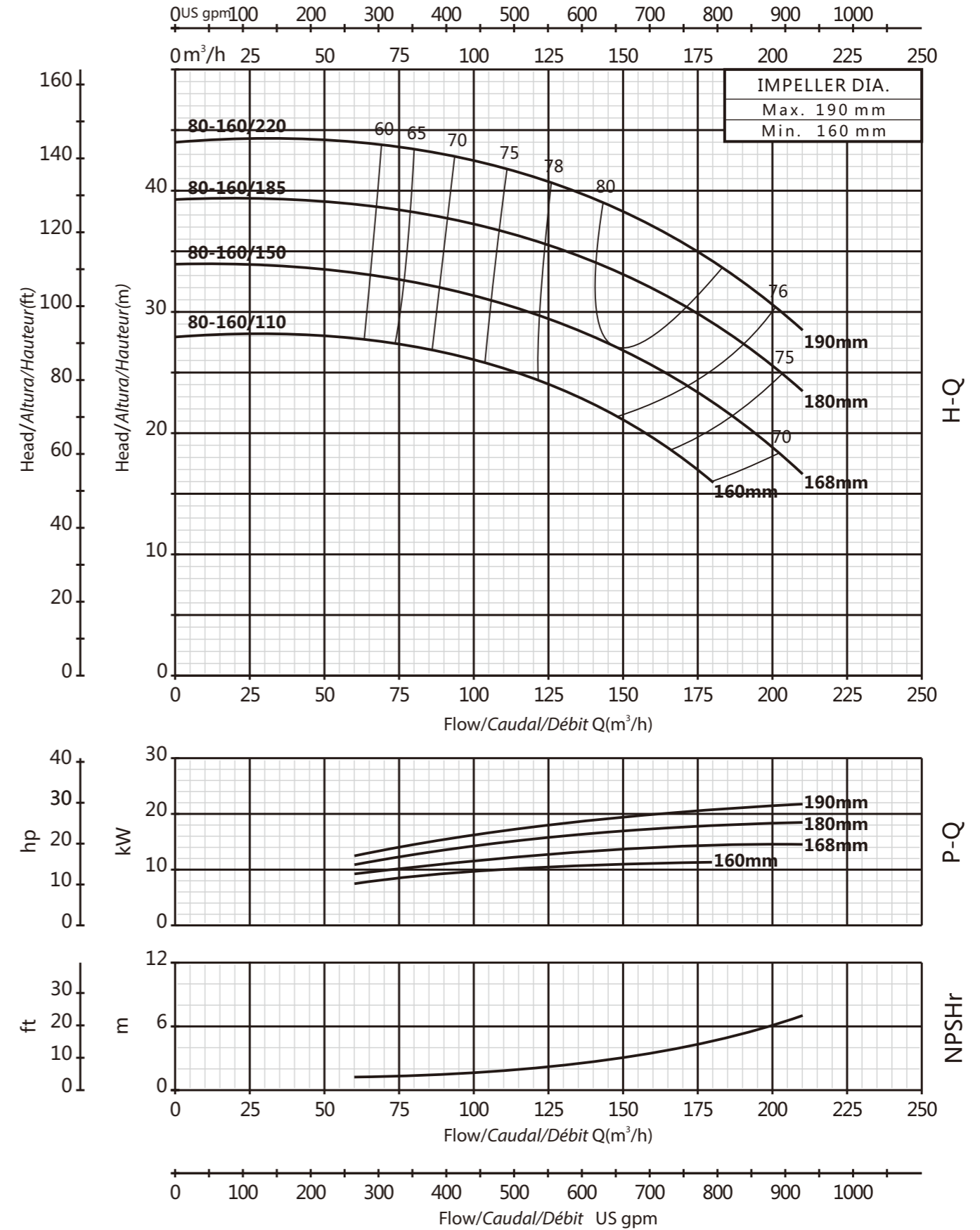

### 80-200

2900rpm

PERFORMANCE CURVE/CURVA DE RENDIMIENTO/COURBE DE PERFORMANCE

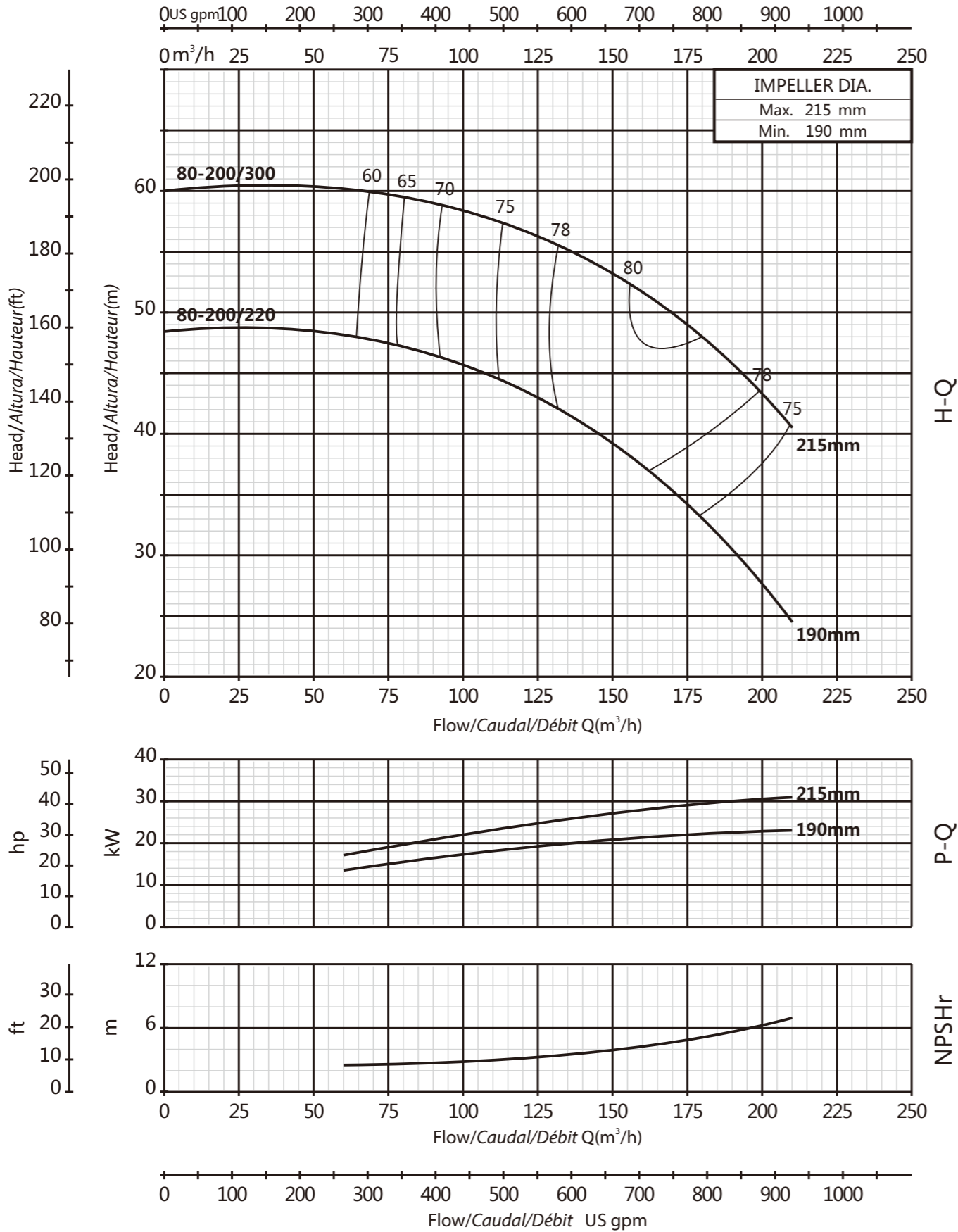

### 80-250

2900rpm

PERFORMANCE CURVE/CURVA DE RENDIMIENTO/COURBE DE PERFORMANCE

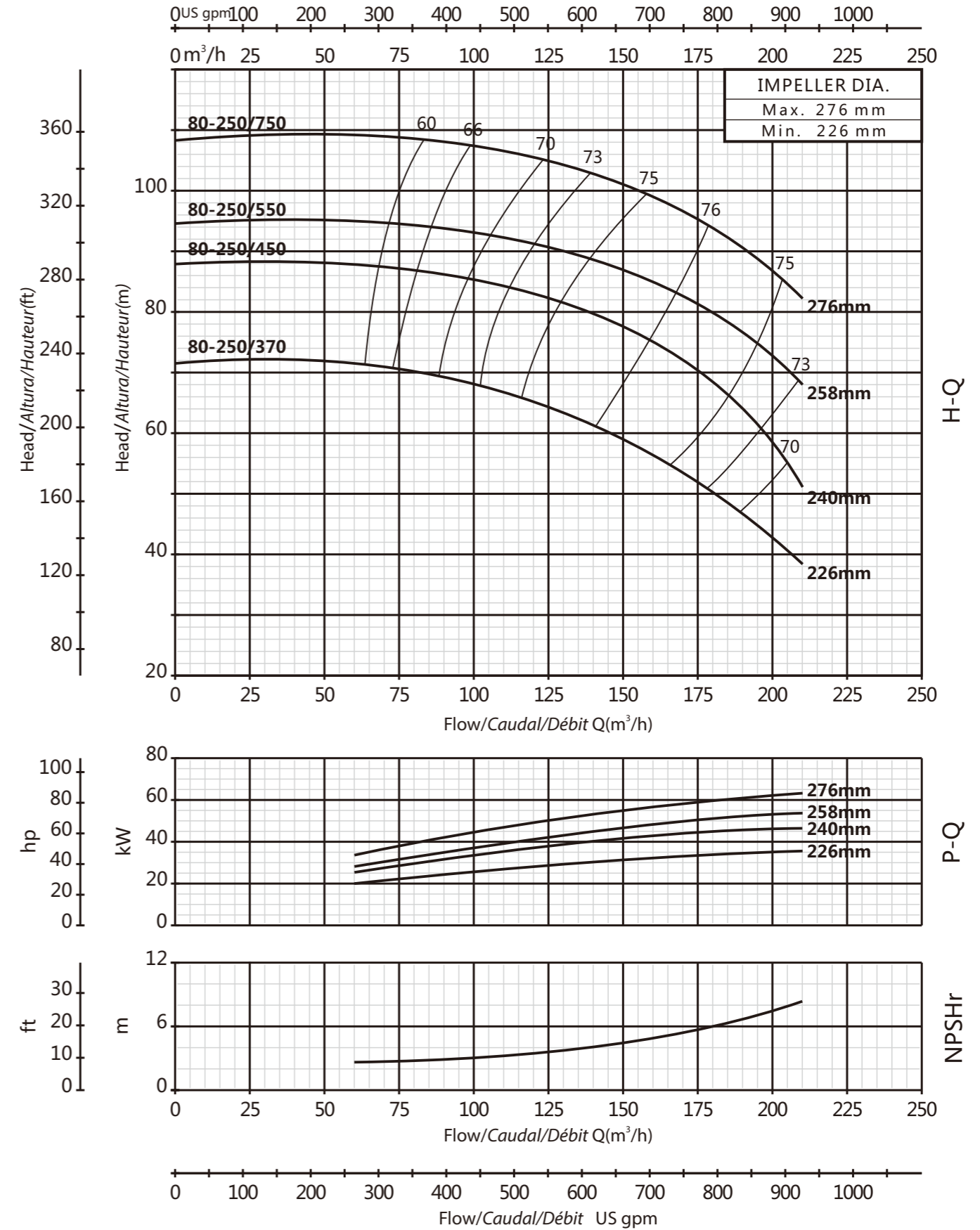

### 80-315

2900rpm

PERFORMANCE CURVE/CURVA DE RENDIMIENTO/COURBE DE PERFORMANCE

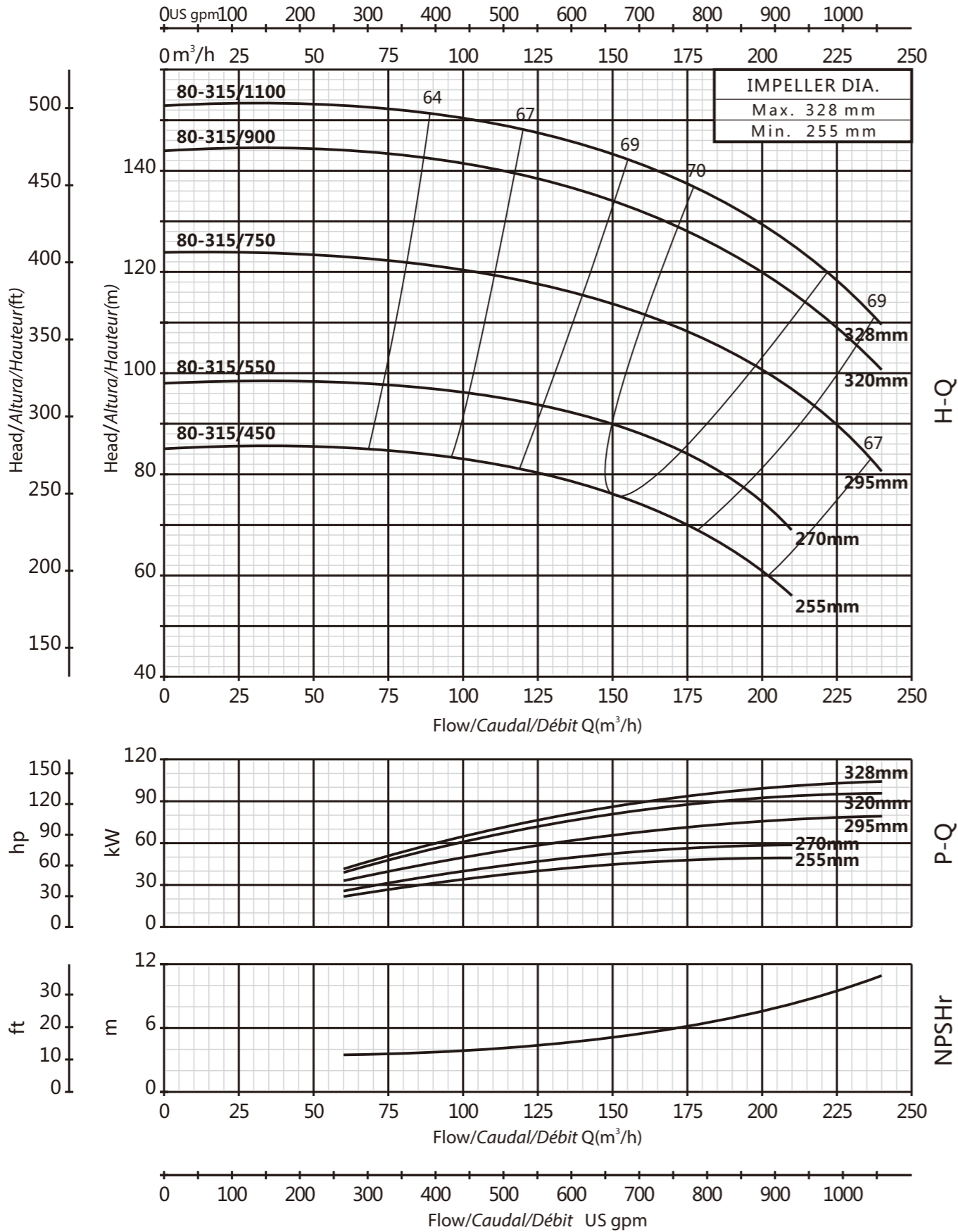

### 100-160

2900rpm

PERFORMANCE CURVE/CURVA DE RENDIMIENTO/COURBE DE PERFORMANCE

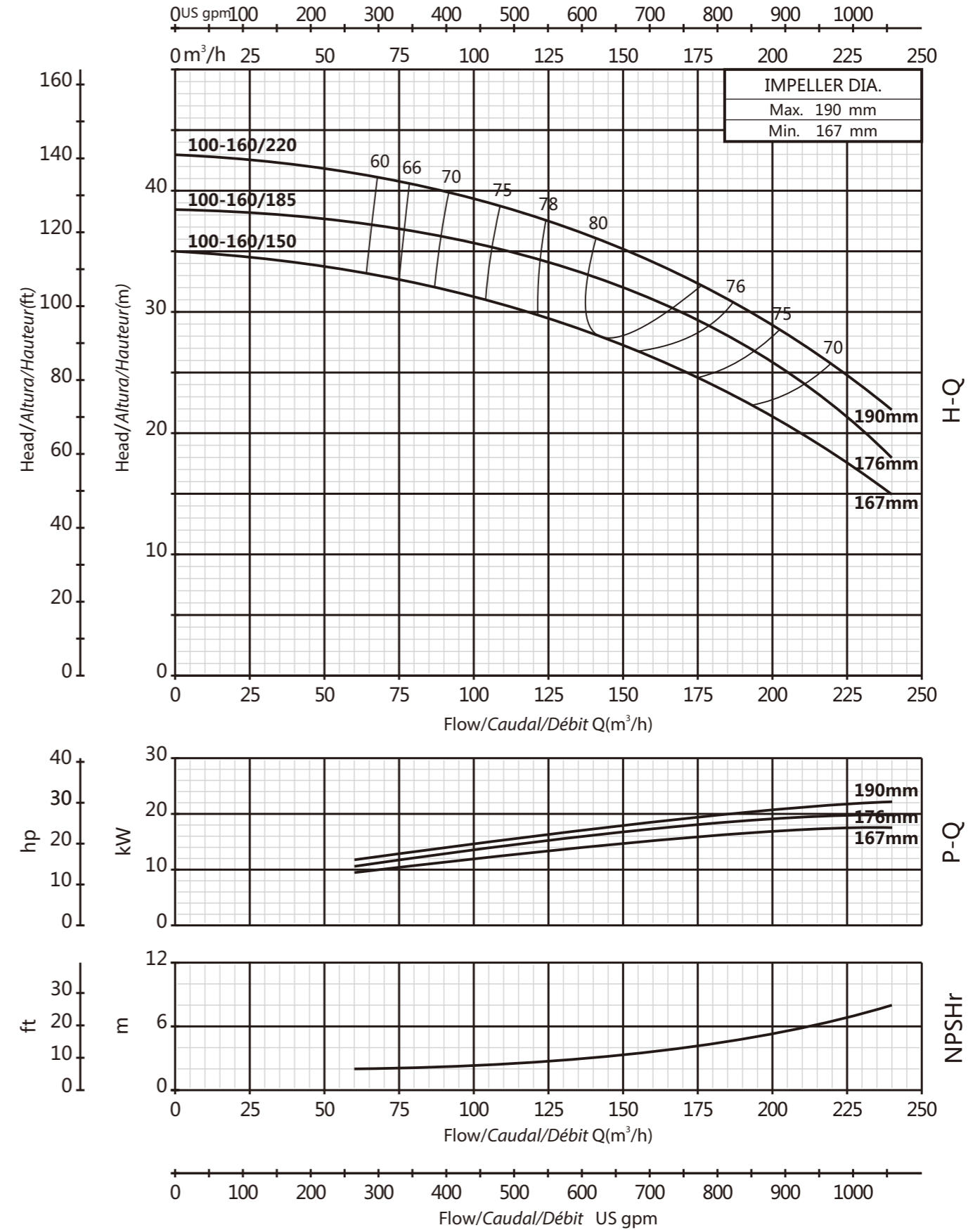

**100-200**

2900rpm

PERFORMANCE CURVE/CURVA DE RENDIMIENTO/COURBE DE PERFORMANCE

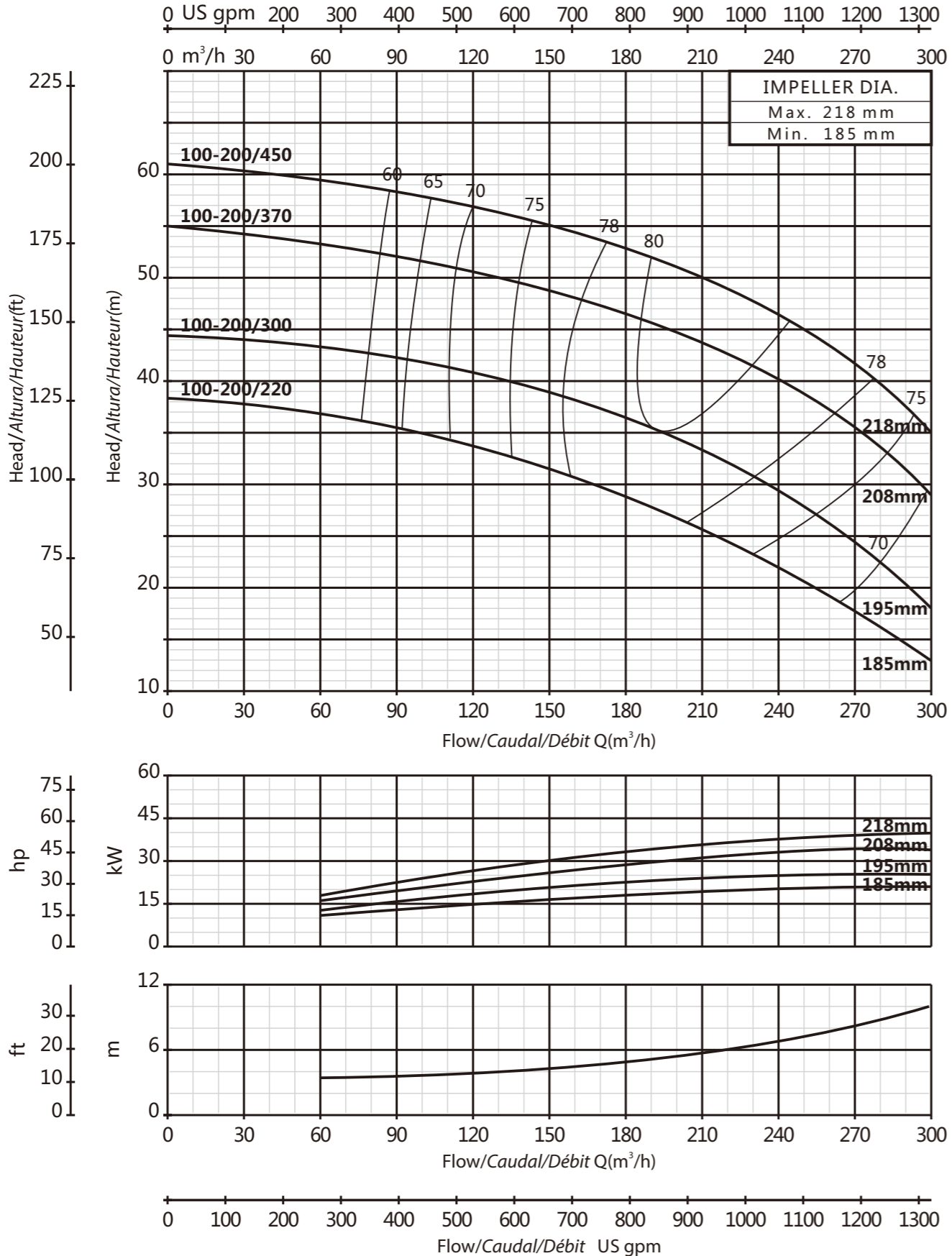

**100-250**

2900rpm

PERFORMANCE CURVE/CURVA DE RENDIMIENTO/COURBE DE PERFORMANCE

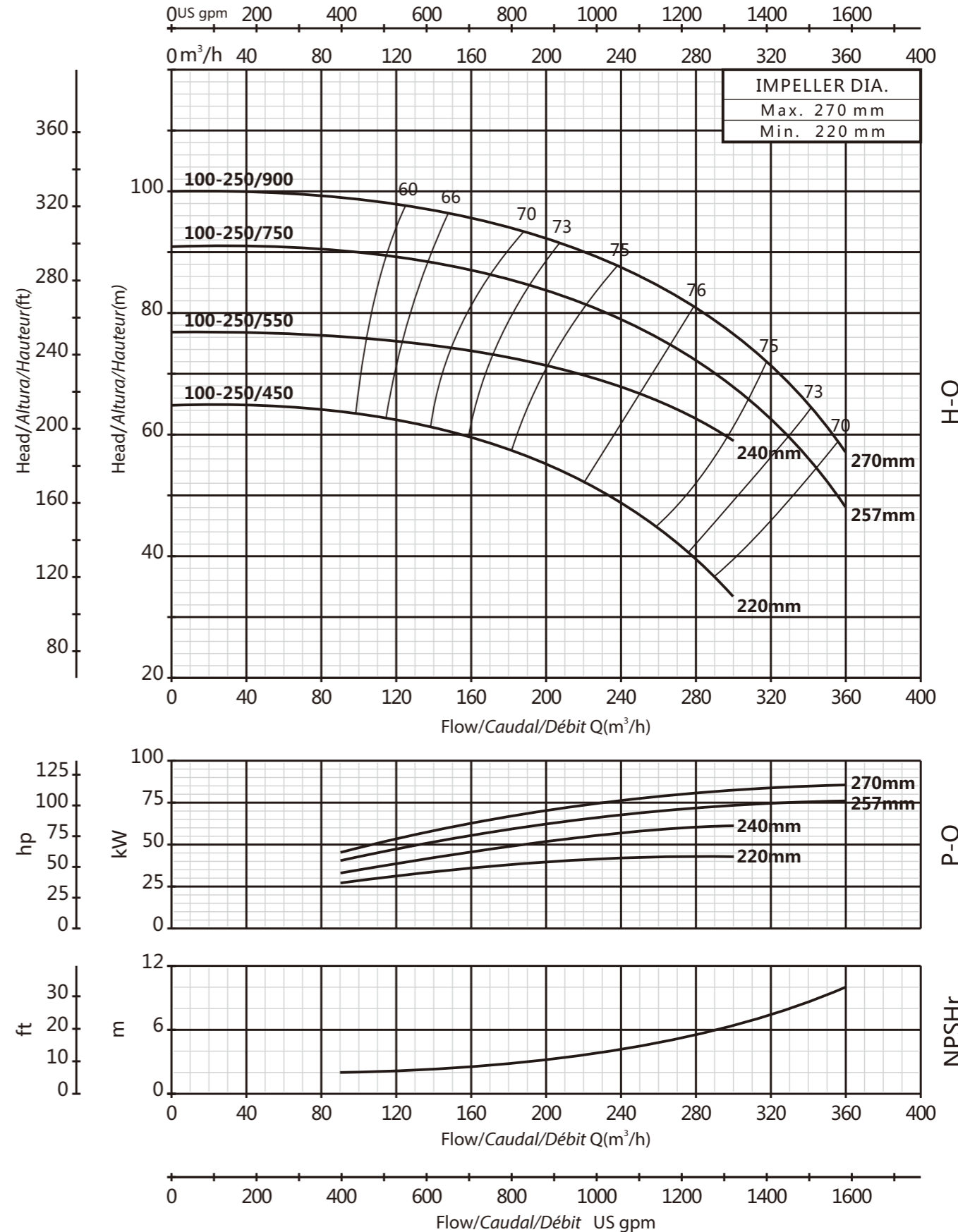

### 100-315

2900rpm

PERFORMANCE CURVE/CURVA DE RENDIMIENTO/COURBE DE PERFORMANCE

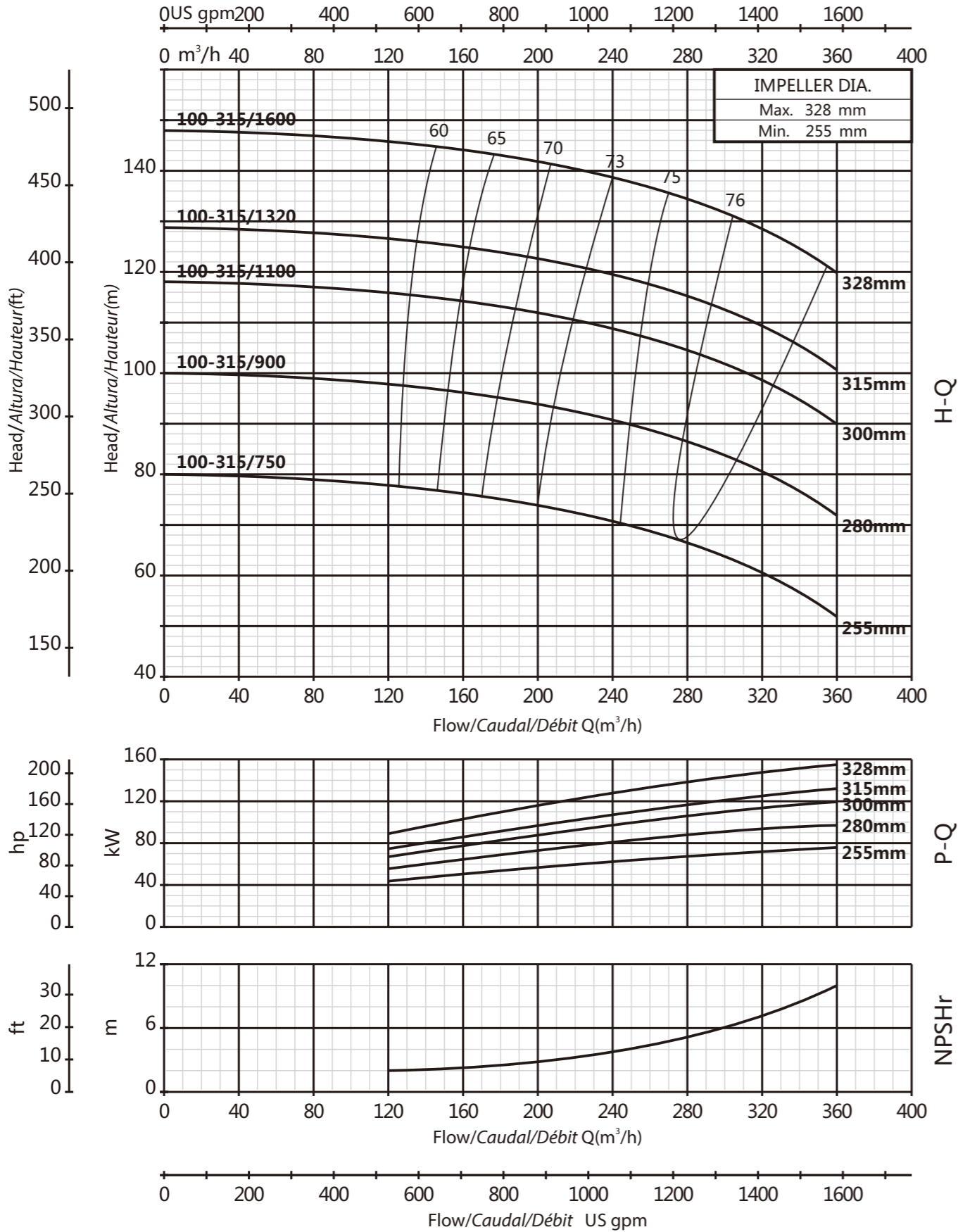

### 125-200

2900rpm

PERFORMANCE CURVE/CURVA DE RENDIMIENTO/COURBE DE PERFORMANCE

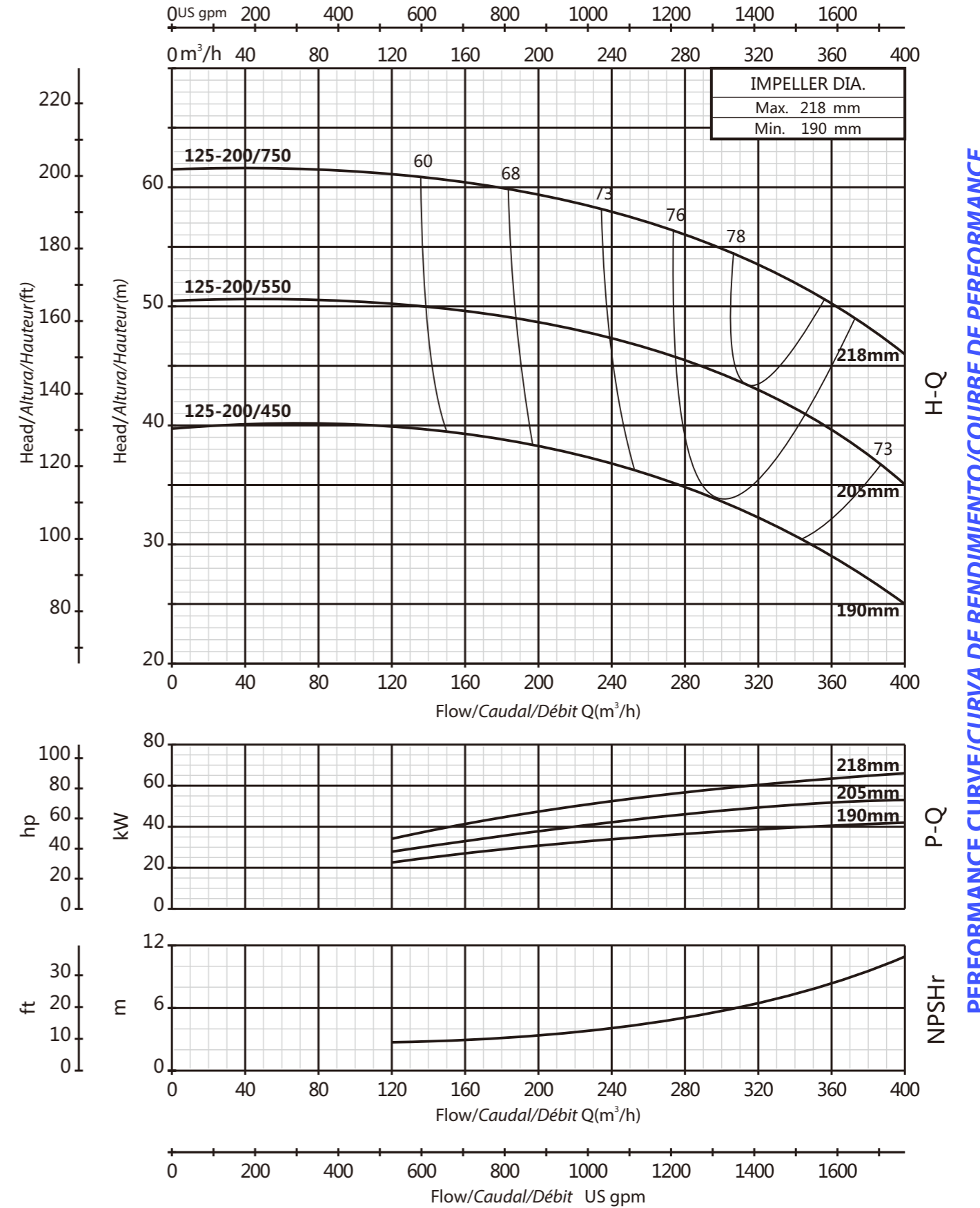

### 125-250

2900rpm

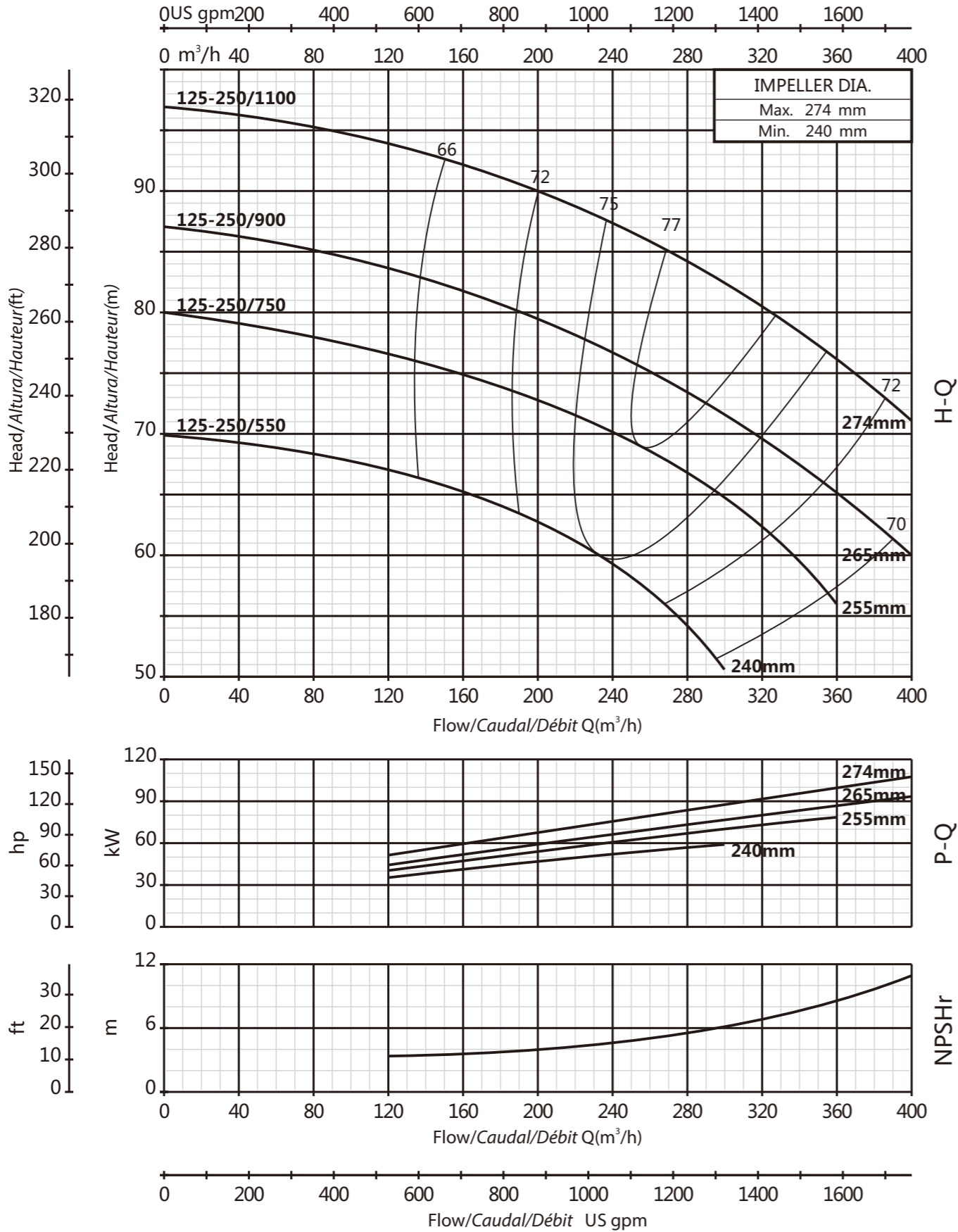

PERFORMANCE CURVE/CURVA DE RENDIMIENTO/COURBE DE PERFORMANCE

### 125-250H

2900rpm

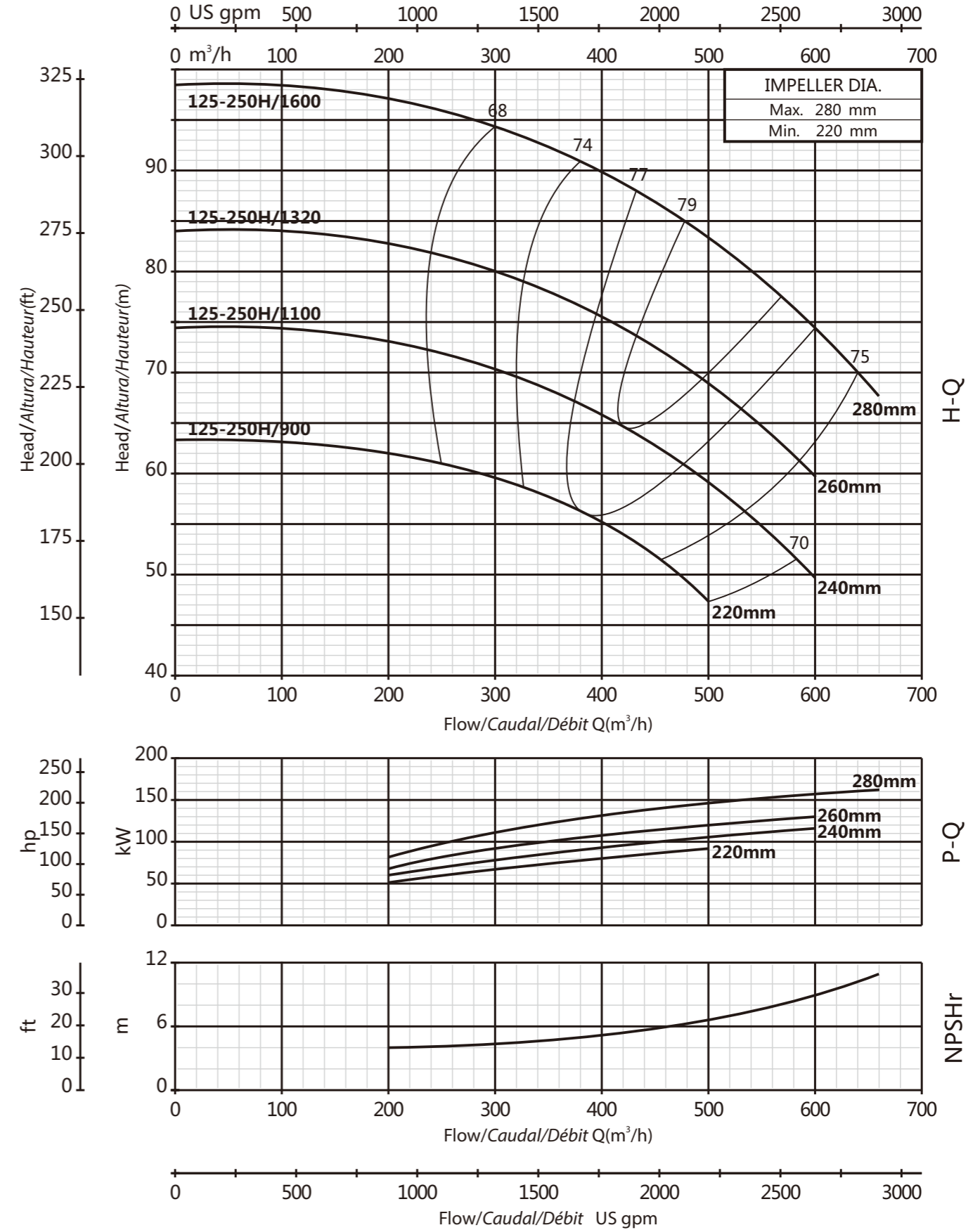

PERFORMANCE CURVE/CURVA DE RENDIMIENTO/COURBE DE PERFORMANCE

### 125-315

2900rpm

PERFORMANCE CURVE/CURVA DE RENDIMIENTO/COURBE DE PERFORMANCE

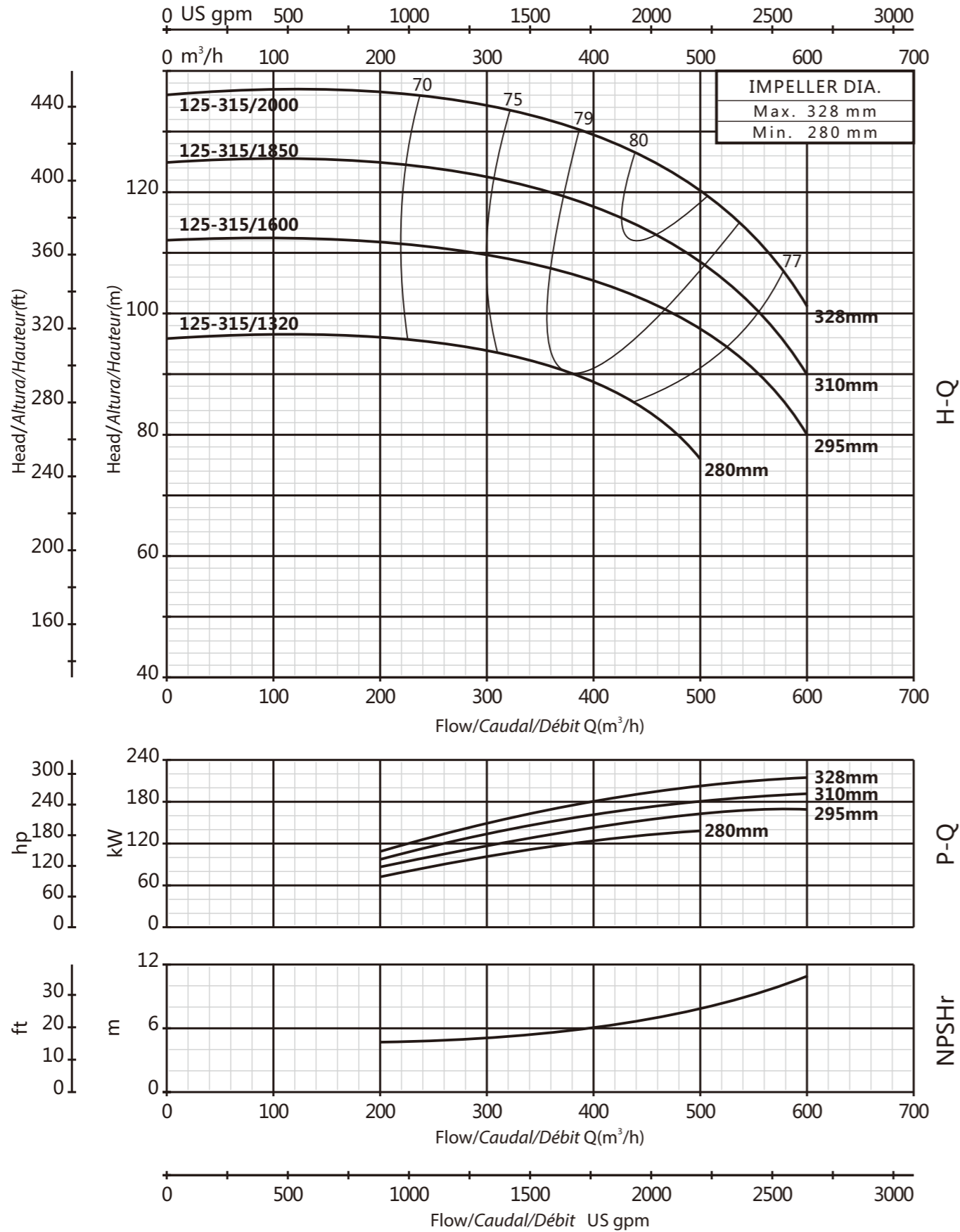

### 150-200

2900rpm

PERFORMANCE CURVE/CURVA DE RENDIMIENTO/COURBE DE PERFORMANCE

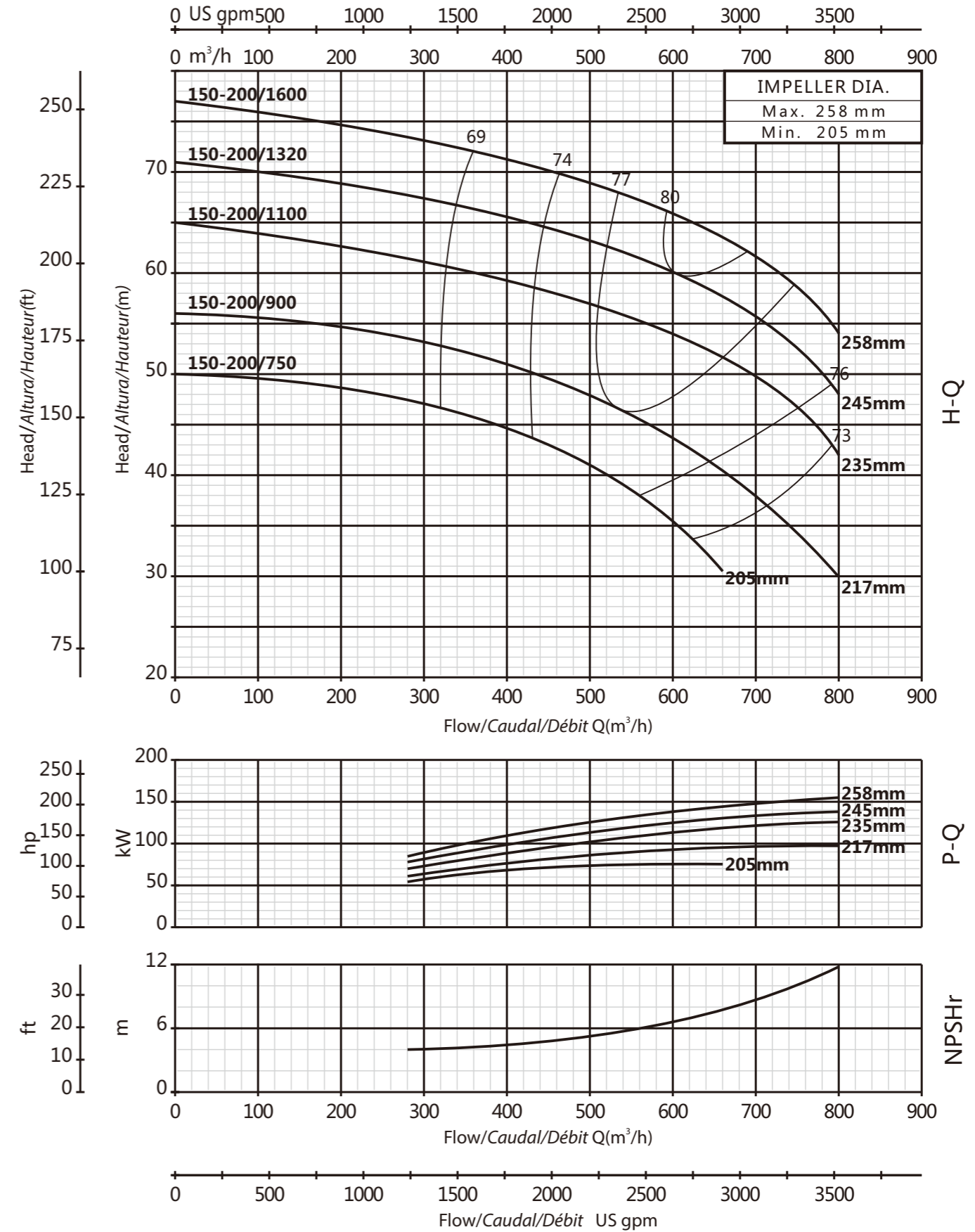

### 150-250

2900rpm

PERFORMANCE CURVE/CURVA DE RENDIMIENTO/COURBE DE PERFORMANCE

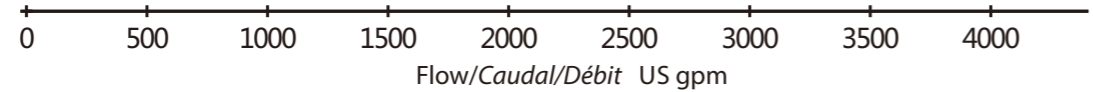
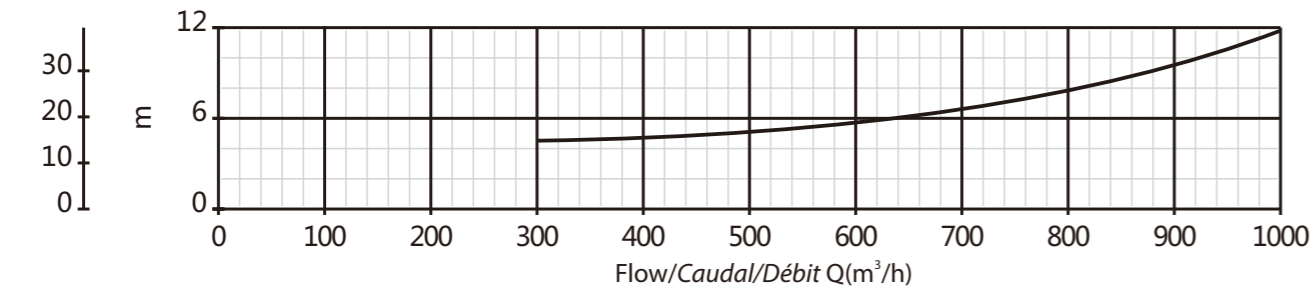
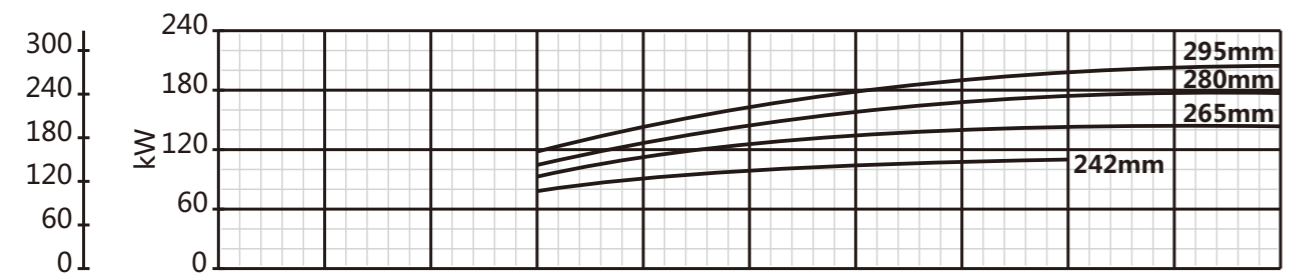
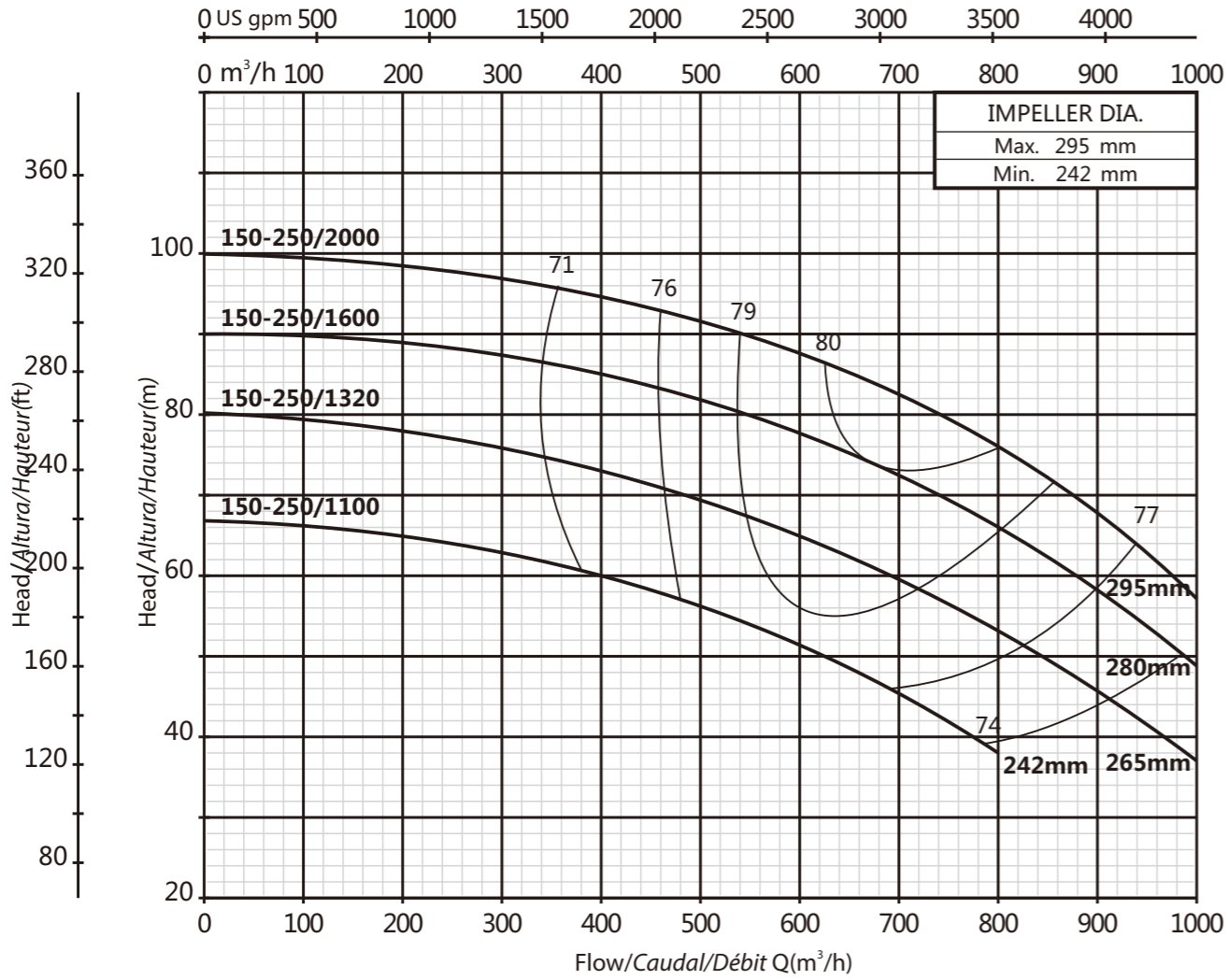

### 150-315

2900rpm

PERFORMANCE CURVE/CURVA DE RENDIMIENTO/COURBE DE PERFORMANCE

